

TRUE RESIDENTIAL 10" 16" & 22" TOUCHSCREEN CONSOLE

TRUE FITNESS



SCAN FOR UP-TO-DATE
OWNER'S MANUAL

**MODELS: CR7-T10A-006/CR7-T16A-006/CR7-T22A-006
MANUAL FOR PERFORMANCE TREADMILL TOUCHSCREEN CONSOLES**

**OWNER'S
MANUAL**

IMPORTANT—PLEASE READ

All products shown are prototype. Actual product delivered may vary. Product specifications, features, and software are subject to change without notice.

For the most up-to-date version of this manual, please see our website:

<https://shop.truefitness.com/customer-service/user-manuals/>

CONTACTING OUR SUPPORT TEAM

To contact TRUE for any of your pre or post installation questions, please call our toll-free numbers Monday - Friday 8:00am - 4:30pm (CST):

- Commercial Direct Customers and Corporate Accounts | 800.868.8783
- Retail Customers and Distributors | 800.883.8783

Or email us:

- Commercial Direct Customers and Corporate Accounts | service.direct@truefitness.com
- Retail Customers and Distributors | service@truefitness.com
- Service International | int.service@truefitness.com

When contacting TRUE, please have the following information ready:

- Serial Number of Unit
- Contact Information—Full Name, Email, and Phone Number
- Address of Facility or Residence
- Detailed Description Regarding Symptom of the Unit (along with pictures or video if applicable)

NOTE: Authorized service providers, dealers, and distributors may also use TRUE's online resource | portal.truefitness.com.

REPORTING FREIGHT CLAIMS OR PARTS DAMAGE

Unfortunately, sometimes materials can be damaged during shipment. If materials are damaged during shipment, please follow the guidelines below to determine the appropriate process for you to follow.

Severe Damage—Obvious damage to external packaging and internal product.

Please refuse the shipment and it will be returned to TRUE by the carrier. Contact TRUE product support by calling 800.883.8783 or sales support by calling 800.426.6570 Monday-Friday during normal business hours to notify us that the shipment has been refused. Once we have received the damaged shipment, a replacement shipment will be sent to you. If the shipment comes in multiple boxes, only refuse boxes with damage.

Slight Damage—Minimal damage to external packaging with unknown internal damage to product.

If the shipment has minimal damages and you are not sure if the actual product is damaged, you must sign the bill of lading as damaged when accepting the shipment. Once you have opened the box and you have determined something is indeed damaged, please gather the serial number, model number, description of damage, and photos of damage. Please make sure the photos include the damaged product as well as the damaged box the product arrived in. Contact TRUE product support (service@truefitness.com | 800.883.8783) or TRUE sales support (sales@truefitness.com | 800.426.6570) Monday-Friday during normal business hours.

Concealed Damage—No damage to external packaging but internal damage to product.

You may receive a shipment that looks intact and discover once the box has been opened that there are hidden damages. Please notify the carrier immediately. TRUE will not be able to file a claim if the carrier is not notified in a timely manner. Once you have called the carrier you will need to gather the serial number, model number, description of damage, and photos of damage. Contact TRUE product support (service@truefitness.com | 800.883.8783) or TRUE sales support (sales@truefitness.com | 800.426.6570) Monday-Friday during normal business hours.

TABLE OF CONTENTS

INSTALL AUXILIARY POWER SUPPLY

REMOVE MOTOR AND PEDESTAL COVERS.....	4
INSTALL AUXILIARY POWER SUPPLY.....	5

ATTACH CONSOLE

ATTACH CONSOLE TO CONSOLE MAST.....	6
MAKE CABLE CONNECTIONS.....	7
CONNECT POWER AND ATTACH COVERS.....	8

INITIAL SETUP

POWERING ON FOR THE FIRST TIME.....	9
CONNECTING TO WI-FI.....	10
CREATING AN ACCOUNT.....	11
CONNECTING TO BLUETOOTH.....	12
STARTING A WORKOUT.....	13
NAVIGATING A WORKOUT.....	14
ENDING A WORKOUT.....	16

CONSOLE FEATURES

FEATURES OVERVIEW.....	17
ICON DESCRIPTIONS.....	18
WORKOUT PROGRAM DESCRIPTIONS.....	20
HEART RATE MONITORING.....	26

CONSOLE NAVIGATION

HOME SCREEN.....	27
USER PROFILES AND PERSONALIZATION.....	28
APPLICATIONS.....	29
MIRRORING.....	30
HDMI.....	31
MACHINE SETTINGS.....	32
APP UPDATES.....	33
MACHINE INFORMATION.....	34

ADVANCED FUNCTIONS

CALIBRATION.....	35
MANAGER.....	36

WARRANTY INFORMATION

LIMITED WARRANTY.....	45
WARRANTY REGISTRATION.....	46

INSTALL AUXILIARY POWER SUPPLY

REMOVE MOTOR AND PEDESTAL COVERS (if not already removed)

1. Remove and set aside the nine (9) screws securing the motor cover and pedestal covers to the treadmill frame.
2. Remove and set aside the covers.

Tools Used in this Step	
#2 Phillips Screwdriver	

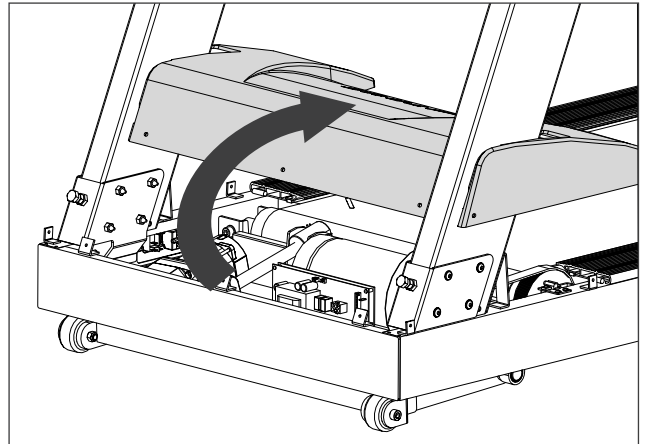
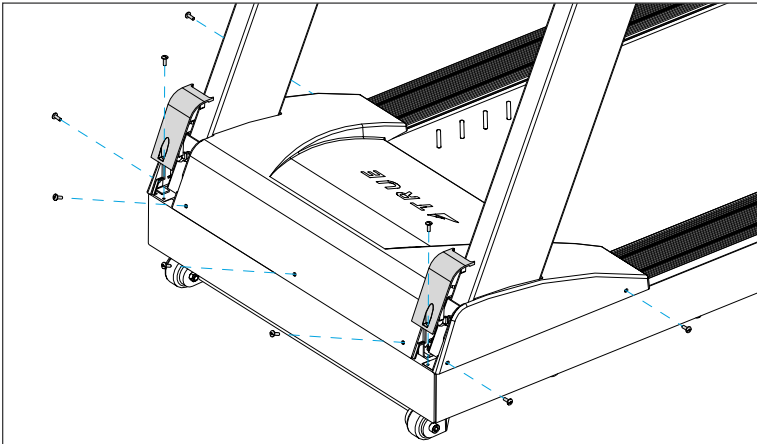

INSTALL AUXILIARY POWER SUPPLY



1. Snip the cable ties securing the power cord in the base.
2. Thread two new cables ties through the existing holes in the base.
3. Place the auxiliary power supply in between the cable ties. Be sure the LED on power supply is facing up.
4. Route the AUXPS power cable from the left pedestal under the incline bracket.
5. Connect the AUXPS power cable to the DC connector on the power supply.
6. Connect the power cord to the power supply.
7. Secure the power supply with cable ties.
8. Snip excess cable tie material.

Tools Used in this Step

Wire Cutters

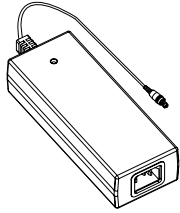

AUXILIARY POWER SUPPLY PARTS NEEDED

Part	Description	Qty
00595500	FUYANG POWER SUPPLY 12V 6AMP 	1
TC6085_005	ZIP TIE 	3

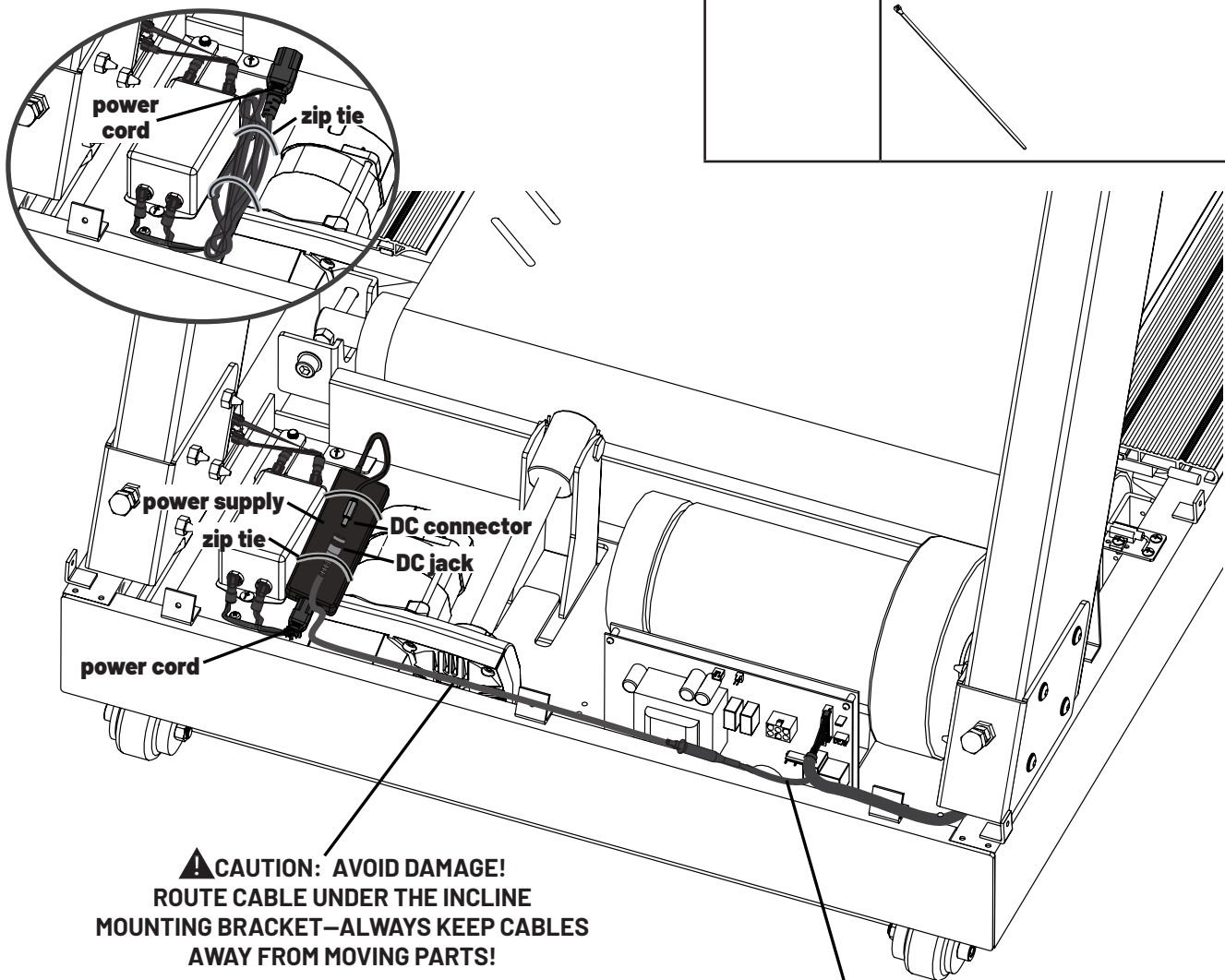

TUCK THE AUXPS DC CONNECTOR FROM THE LEFT PEDESTAL OUT OF THE WAY

ATTACH CONSOLE

ATTACH CONSOLE TO CONSOLE MAST

Using a #2 Phillips screwdriver, secure the console to the console mast using the hardware preassembled to the console.

NOTE: If the console also has three smaller screws preassembled, remove and set aside these screws. They are not used in this installation.

NOTE: Loosen but do not remove the bottom two preassembled screws, those slide into the keyhole slots on the console mast.

Tools Used in this Step	
#2 Phillips Screwdriver	

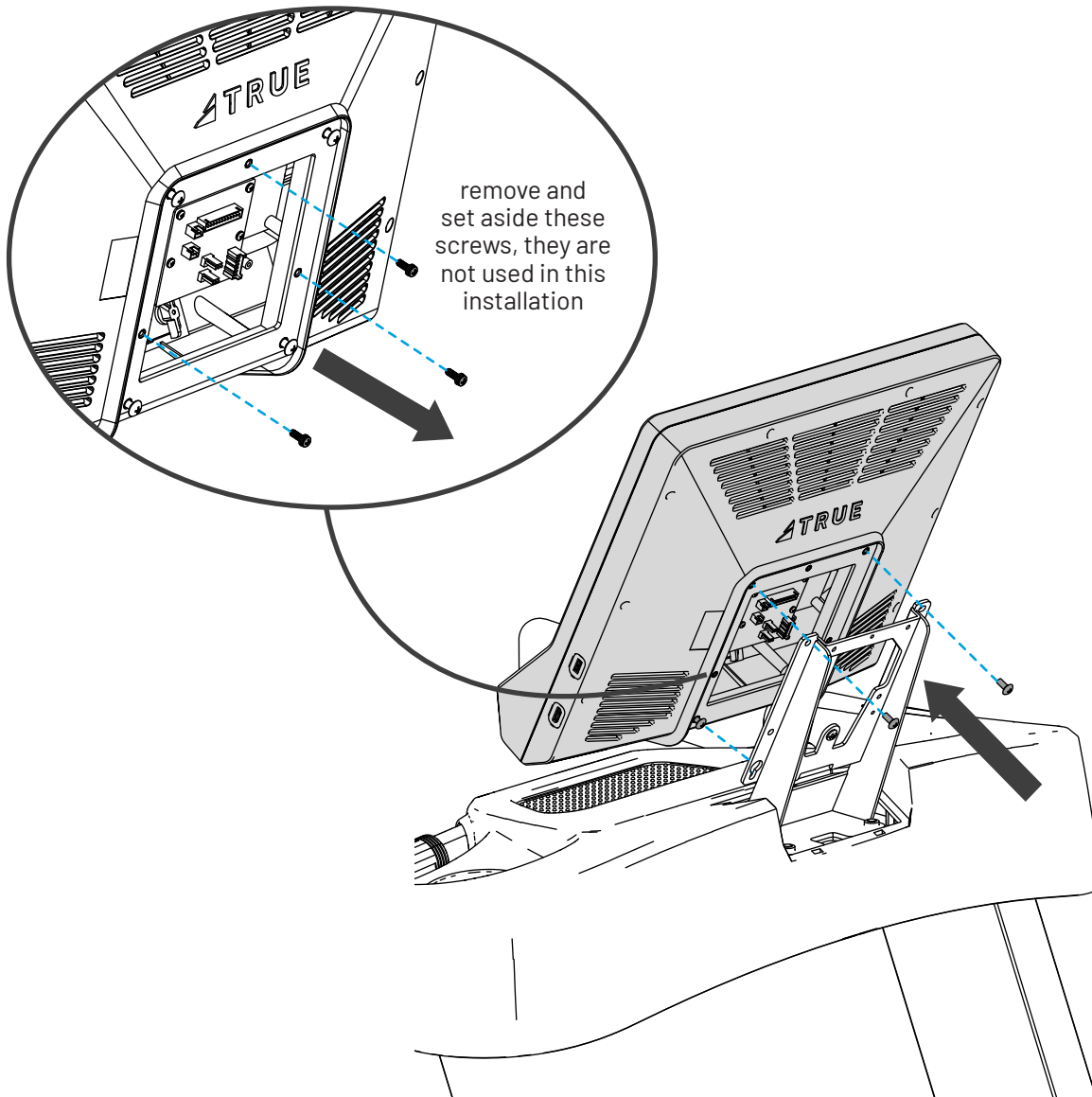

MAKE CABLE CONNECTIONS

1. Connect the I/O cable, center pod cable, and safety key cable to their respective ports on the console control board.

NOTE: The shorter safety key connector pictured below is used for this console. The longer connector will not be used.

2. Connect the heart rate cables.
3. Connect all four ground wire ring terminals to the preinstalled ground screw on the console mast. Ensure all four ground wire ring terminals are connected to the mast with the screw.

Tools Used in this Step

#2 Phillips
Screwdriver

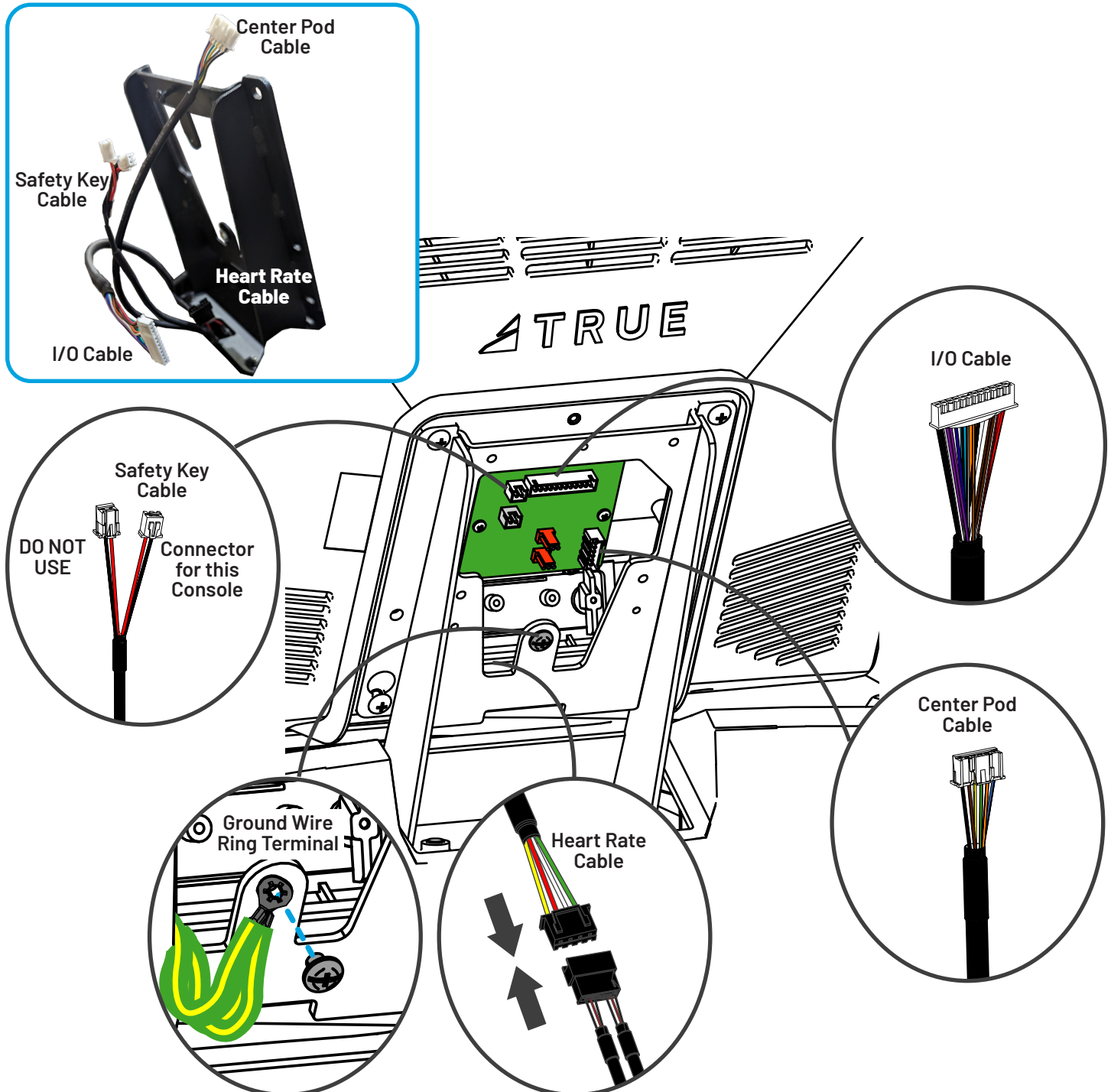

CONNECT POWER AND ATTACH COVERS

1. Connect the power cord into the power inlet and then power on the treadmill. Verify the console powers up.
2. Secure the rear console cover to the console mast.
3. Attach the motor cover.
4. Using the previously removed nine (9) screws, secure the motor cover and pedestal covers to the frame.

Tools Used in this Step

#2 Phillips
Screwdriver

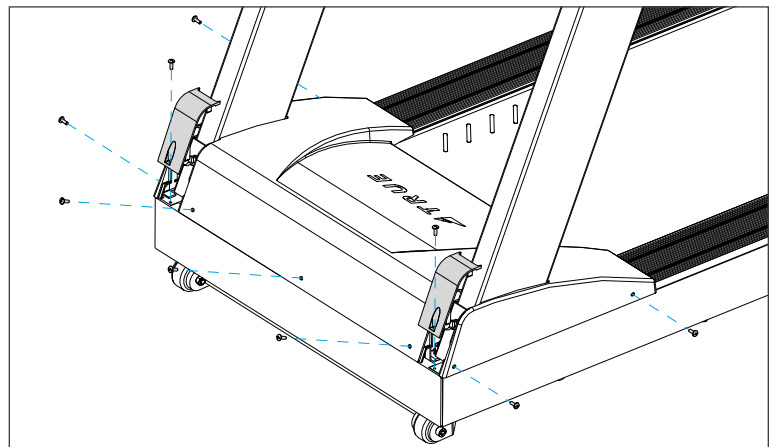
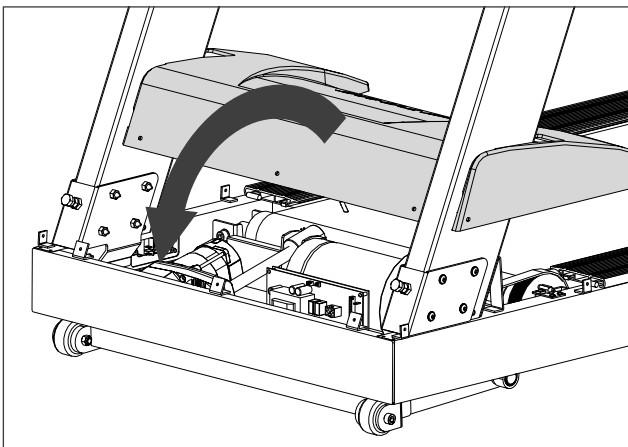
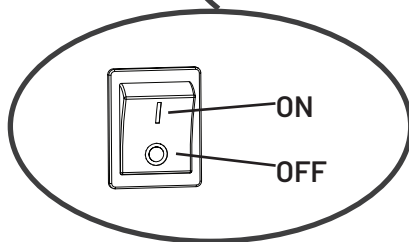
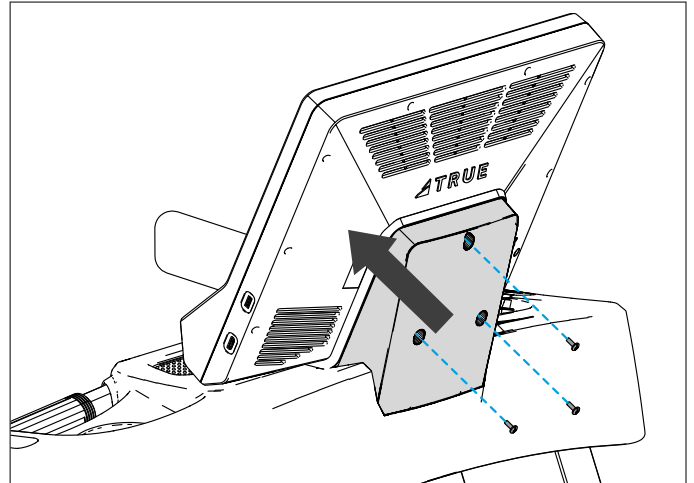
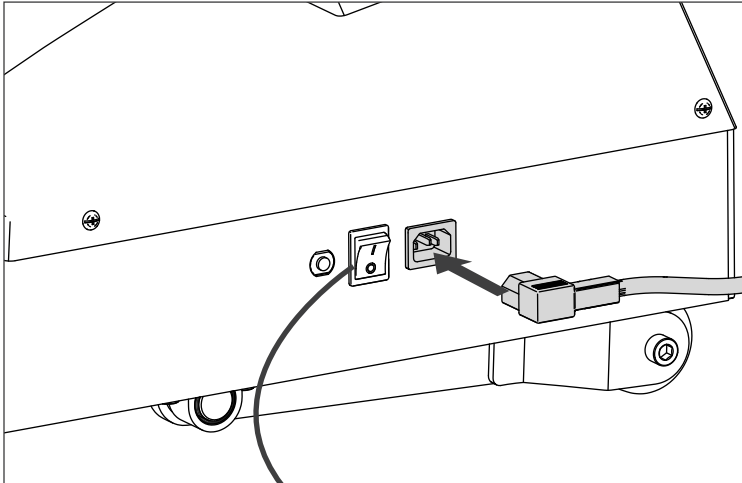

INITIAL SETUP

POWERING ON FOR THE FIRST TIME

When the console is powered on, it will start to detect whether there is a network in the environment. When it is turned on for the first time, it will be in a no-network state. You can:

- Press **Go Setting** to set up the Wi-Fi (recommended).
OR
- Press **GUEST** to go directly to the home screen. You can use the treadmill without an account. However, some features of the treadmill will not be available without an account.

NOTE: An internet connection is required to:

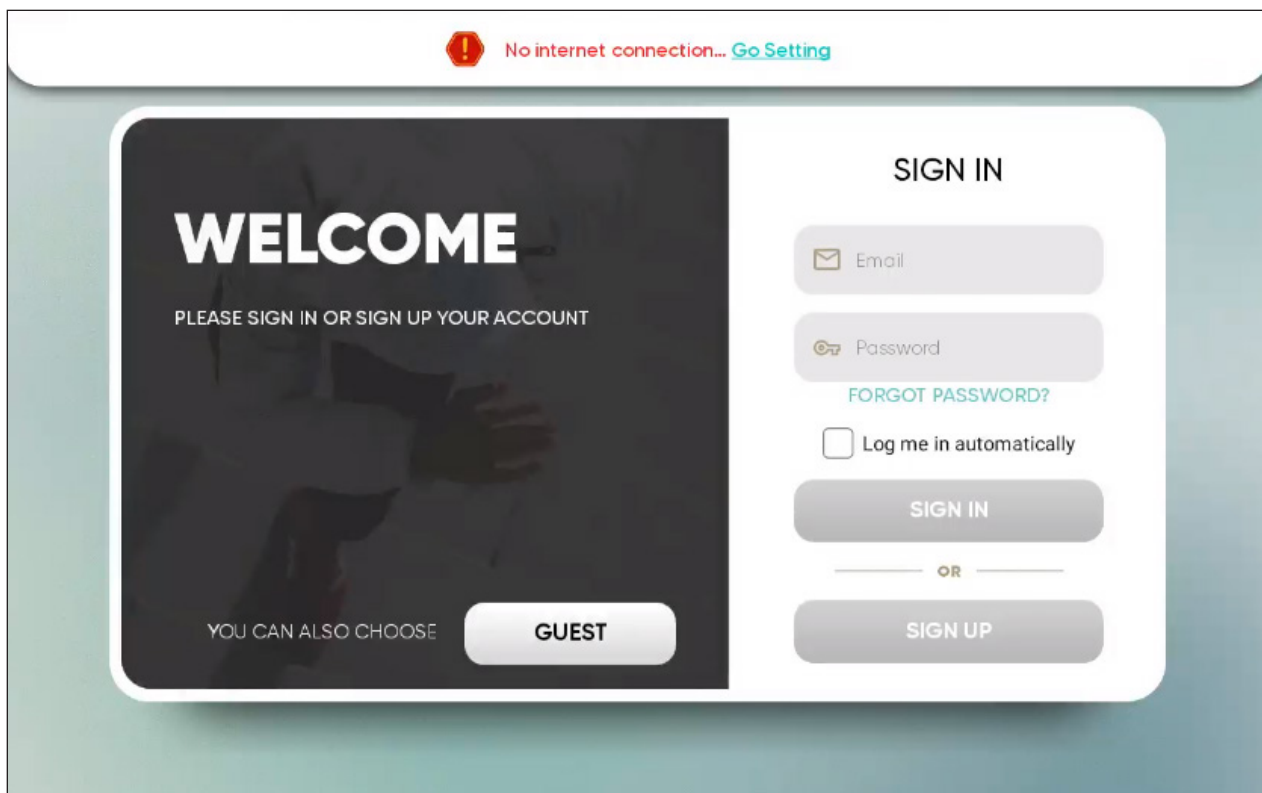

- Sign in or sign up for user accounts. With a user account, all features of the treadmill are activated.
- Use third party entertainment and media apps.
- Do software updates over the air.



NOTE: The image above may differ from your console.

CONNECTING TO WI-FI

You can access the Wi-Fi set up screen by pressing:

- **Go Setting**  during initial console power up.
- The Wi-Fi icon .
- **SETTING** → **Connection Setting** → **wi-fi** .

To see available networks, turn Wi-Fi on. Press the slider  to use Wi-Fi.

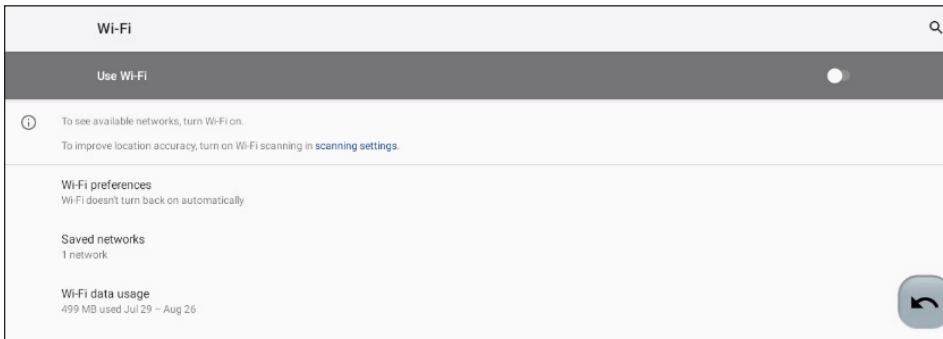

NOTE: The image above may differ from your console.

When the **Use Wi-Fi** slider is active , the console will scan for available networks.

When Wi-Fi is active you can add a network, modify your Wi-Fi preferences, turn on scanning, view saved networks, and view data usage.

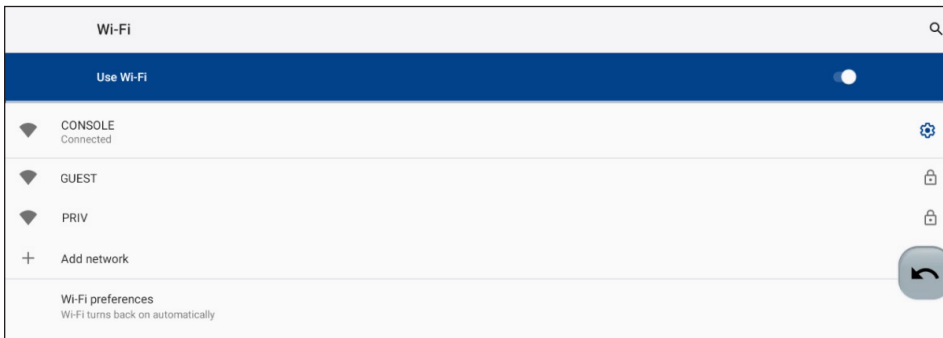

NOTE: The image above may differ from your console.

When you are done setting up the Wi-Fi connection, press the return button  to go back to the home screen.

CREATING AN ACCOUNT

NOTE: The console needs to be connected to the internet to create a new account or access an existing account.

To create a new user account:

1. Press **SIGN UP** from the **WELCOME** screen.

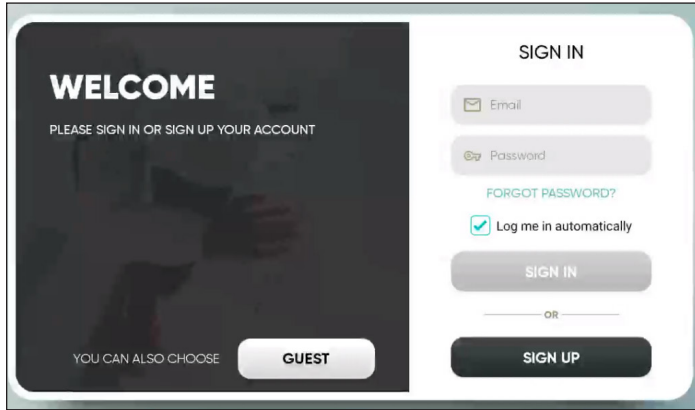

2. Fill out the information on the **SIGN UP** screen. When all the information has been entered correctly and verification is complete, press the next button to continue.

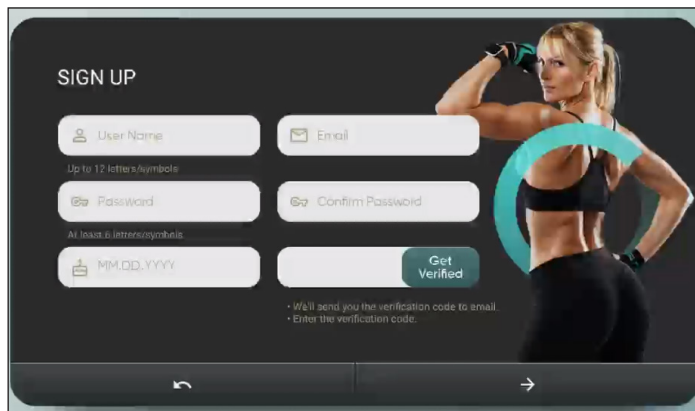

NOTE: You must enter a valid verification code before you will be able to continue.

3. Using the buttons on the screen, enter the height, weight, and gender information. When all the information has been entered, press the next button to continue.

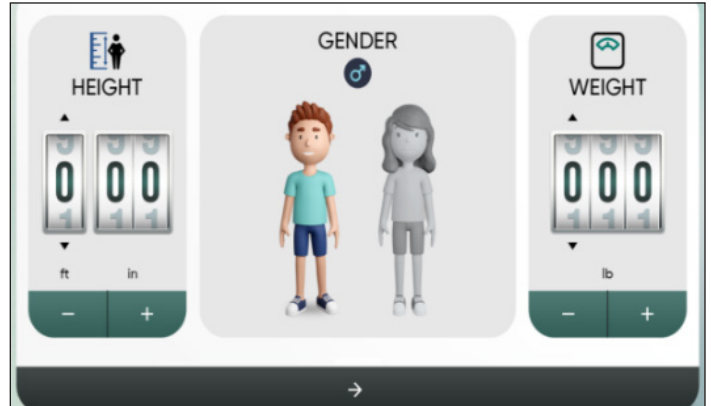

NOTE:

- **HEIGHT**
Default Value: 63" (160cm)
Settable Range: 39" - 98" (100cm - 250cm)
- **WEIGHT**
Default Value: 155lb (70kg)
Settable Range: 44lb - 440lb (20kg - 200kg)

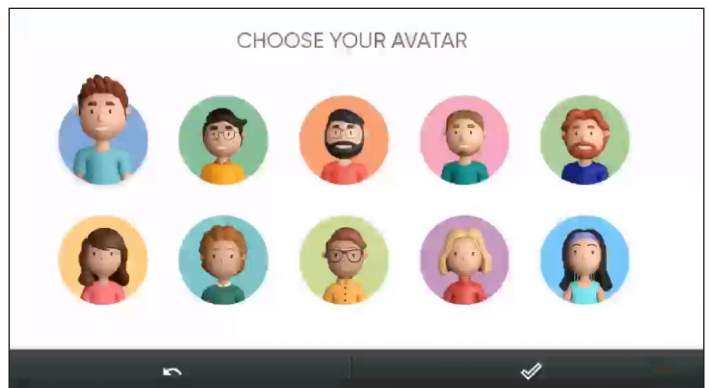

4. Select an avatar for your user profile, and then press the confirm button .



The user account is created, and the home screen is displayed with the new user profile active.

CONNECTING TO BLUETOOTH



BLUETOOTH HEART RATE

When Bluetooth is turned on, the system will automatically scan for nearby Bluetooth devices. Tap the name of the device you wish to connect to. If the pairing is successful, press Back  to return to the settings page, and then press Home  to return to the Idle Mode. If pairing fails, no connection will be established.



PAIRING A BLUETOOTH DEVICE

1. With the console active, press the Bluetooth icon .

You can also access Bluetooth by pressing **SETTING** → **Connection Setting** → **Bluetooth** .

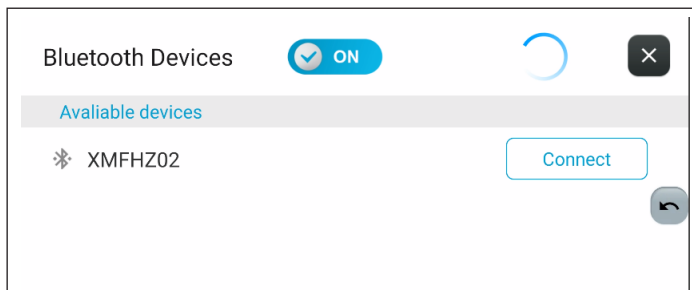
2. On the Bluetooth Devices screen, ensure the connection is turned on  and the system will automatically scan the surrounding Bluetooth.
3. Activate your Bluetooth device and put it into pairing mode. Follow the instructions provided by the manufacturer to pair or connect it.
4. Once the Bluetooth device is found, the console will list it as an available device.
5. Press **Connect** . The device will be connected.



6. To disconnect your device, press **Disconnect**  from the list of connected devices. To delete a paired device press the trash can .

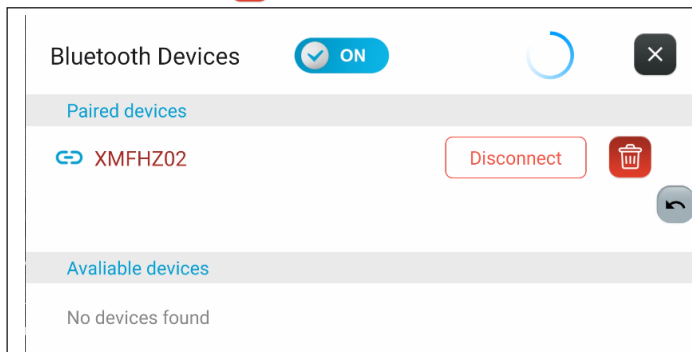

BLUETOOTH APP CONNECTION

Kinomap



1. Register and log into the Kinomap app on your phone/console.
2. Tap "More equipment" → Fitness Equipment page.
3. Tap "+" on the top right → Select Treadmill and FIMS brand.
4. Tap My Treadmill → Select FTMS protocol.
5. Connect to the Bluetooth name "Anplus-XXXXX".
Once added, data on the app will sync with the console in real time.

Zwift

1. Register and log into Zwift app.
2. In the pairing screen, select Running → Speed.
3. Find and connect to "Anplus-XXXXX", then tap OK.
Once connected, speed data will sync with the console.
If the console has not started a workout, speed and heart rate will show 0.





NOTE: The console cannot connect to Bluetooth while in Engineering Mode (Advanced Console Functions).

STARTING A WORKOUT

You can access workouts by pressing **QUICK START**  or by pressing **PROGRAM**  and choosing from one of the programs available on the console.

Choosing **QUICK START** will begin a workout after a 4 second countdown. No Warm Up or Cool Down is provided. All settings are controlled by the user.

Choosing **PROGRAM** allows you to scroll through the available categories of workouts (Classics, Vision Run, Fitness Test, Heart Rate Control (H.R.C.), User Program, Intervals, and Marathon). If the workout has additional categories use the scroll buttons to see all of the categories.

Press a workout to select it and then press the **ENTER**  button. If you want to use the system defaults for the program, press the start  button. If you would like to edit the program defaults use the plus  or minus  buttons to change the parameters. If you would like to edit the user profile, click the edit pencil  to make changes.

NOTE: The images shown may differ from your console.

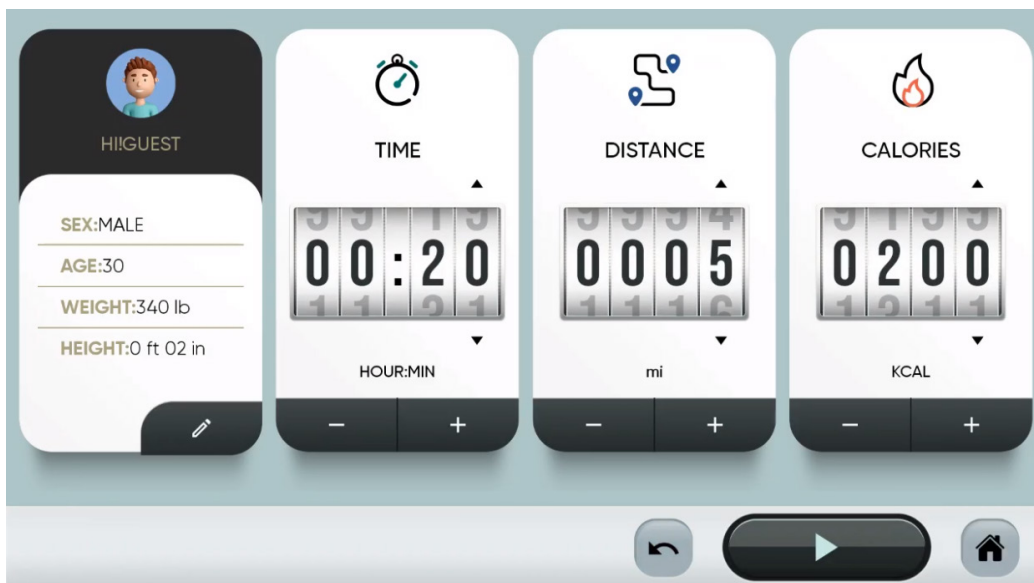
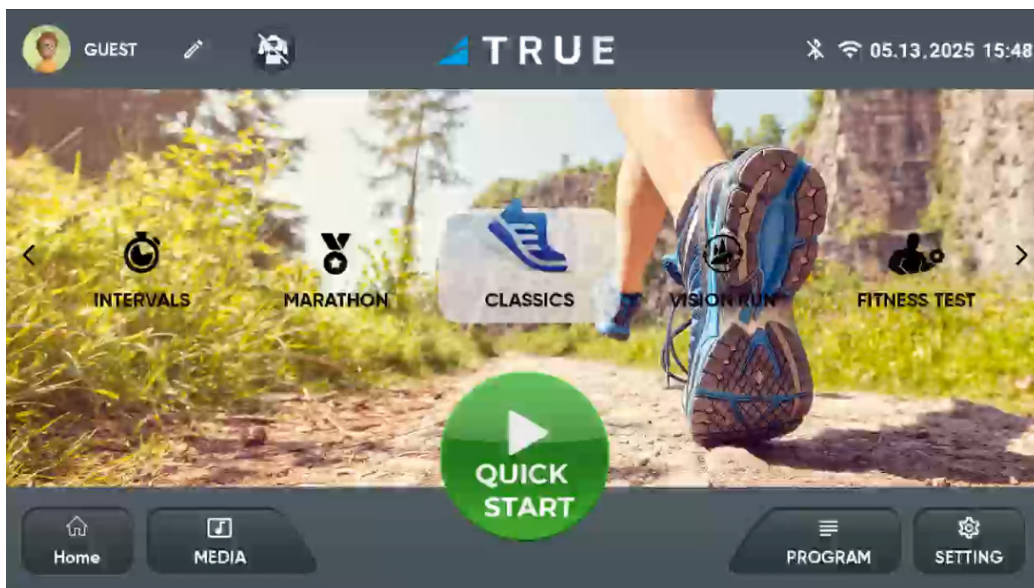

NAVIGATING A WORKOUT

After you press start for your chosen workout, there will be a 4 second countdown before the workout begins. Some workouts have a 3 minute Warm Up before the workout begins. To directly start the workout, press **SKIP**.

MIRROR: Share the screen of your device on the treadmill display during a workout.

APPLICATIONS: Tap to select a pre-installed application to be displayed on the screen during the workout.

WORKOUT PROFILE: The Workout Profile shows the incline or speed settings across the workout, with the workout time starting at the left and increasing to right. The active segment in the Workout Profile shows the current column of the workout.

Each Workout Profile has an Incline and a Speed Profile. Tap on the Incline or Speed Tab under the Workout Profile to switch between the Incline and a Speed Profile. The higher the column, the higher incline or speed setting for that segment of the workout.

During a workout with a Workout Profile, the console will make two audible beeps to notify the user that the speed is going to change.

LAPS PROFILE: The Laps Profile shows virtual track that has an outer and an inner lap, both of which are 0.25 miles long. If the screen shows the Workout Profile, tap the Lap Profile button to change to the Lap Profile display.

BLUETOOTH: Press to open the Bluetooth screen and select an available device to connect. Select the desired device, and then tap Connect.

WI-FI: Shows if the treadmill is connected to a Wi-Fi connection.

DISTANCE: Shows the Distance (km or mi) of the workout. The displayed value will count down if Distance was a goal.

INCLINE: Shows the current incline grade of the running deck.

TIME: Shows the time for the workout. The displayed value will count down if Time was a goal.

CALORIES: Shows the estimated calories burned for the workout. The displayed value will count down if Calories was a goal.

HEART RATE: Shows the current heart rate in beats per minute (bpm) for the wearer of a connected Bluetooth Heart Rate device.

Time: Elapsed Time, Target Time, or Remaining Time

Calories: METS, Calories, Calories/HR, or Elevation Gain

Heart Rate: Maximum HR, Average HR, or Heart Rate

NOTE: The images below may differ from your console.

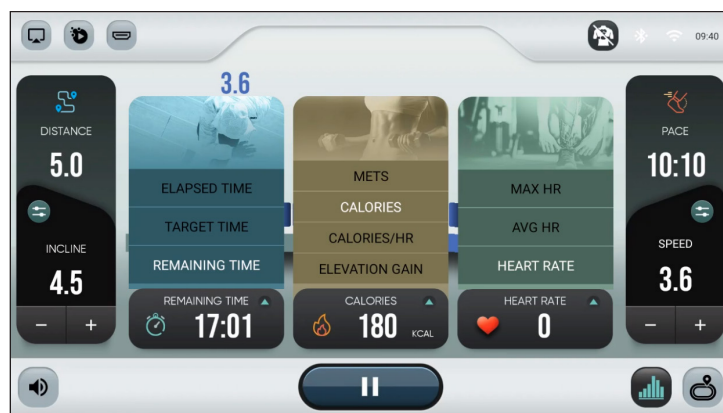
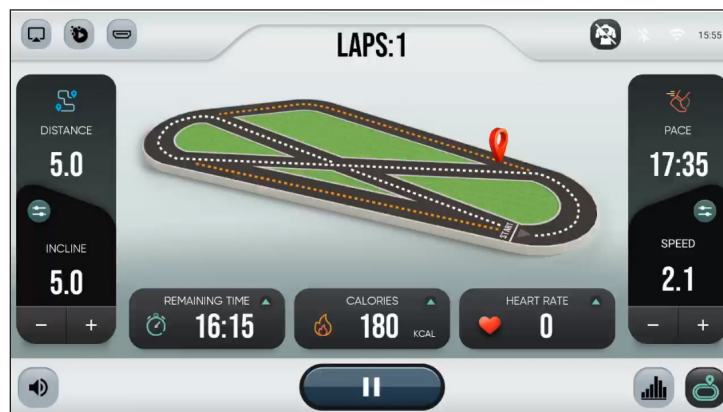
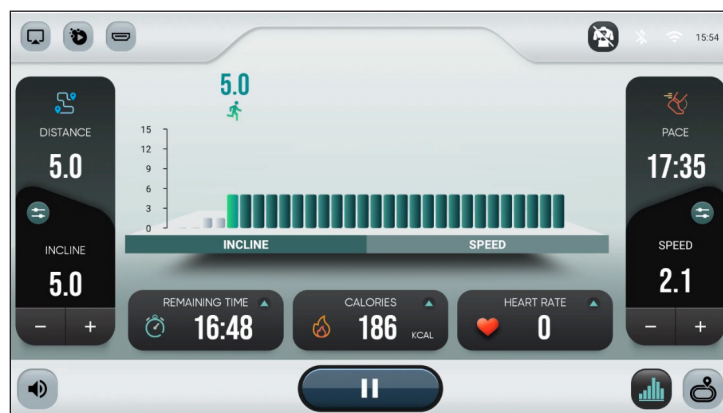
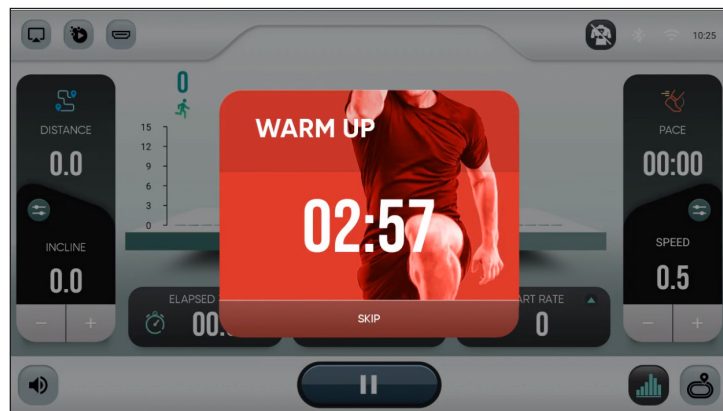

NAVIGATING A WORKOUT CONTINUED

 **PACE:** Shows an estimated time that it would take to complete a kilometer or a mile at the current workout values.

 **SPEED:** Shows the current speed (kph or mph) of the running belt.

 **WORKOUT VOLUME:** Adjust the volume for the workout with the + and - buttons.

 **PAUSE:** Pauses an active workout bringing the running belt to a stop and the incline to 0. A pause window is displayed, with the options RESUME or FINISH.

NOTE: If a workout is paused for over 5 minutes, the workout is ended and the treadmill displays the workout results. When a paused workout is resumed, speed and incline will gradually return to the levels when the workout was paused.

 **INCLINE/SPEED PROFILE:** Tap to switch the Workout Profile from the Laps Profile to Incline/Speed Profile.

 **LAPS PROFILE:** Tap to switch the Workout Profile from the Incline/Speed Profile to Laps Profile.

EMERGENCY STOP: If the Safety Key is removed during a workout the belt will stop immediately, the workout is ended, and the Emergency Stop (Please Reinsert the Safety Key) screen is displayed. When the Safety Key is inserted back into the machine, the Home screen will be displayed.

NOTE: The images below may differ from your console.



ENDING A WORKOUT

To end a workout, press the pause button , and then press **FINISH** and the workout summary screen appears.

TIME: Shows the total time of the workout.

TOTAL DISTANCE: Shows the total distance (km or mi) of the workout.

CALORIES: Shows the estimated total calories burned during the workout.

PACE (AVERAGE): Shows the average time to complete a kilometer or mile during the workout.

MAXIMUM SPEED/ELAPSED TIME: Shows the maximum speed of the running belt during the workout and when it occurred.

METS: A MET is a ratio of your workout metabolic rate relative to your resting metabolic rate. Your resting metabolic rate is 1 MET, so the displayed number of METS is the intensity level of exertion above the sitting at rest level.

SPEED AND HEART RATE GRAPH: Graphic representation of the speed of the running belt throughout the entire workout, with the recorded heart rate value charted on it. Tap  for more details.

INCLINE AND HEART RATE GRAPH: Graphic representation of the incline grade of the running deck throughout the entire workout, with the recorded heart rate value charted on it. Tap  for more details.

SAVE WORKOUT TO USER: Tap to save the workout.

 **SHARE WORKOUT RESULTS:** Use pre-installed applications to share your workout.

 **HOME:** Goes to the Home or Idle screen.

NOTE: The images below may differ from your console.

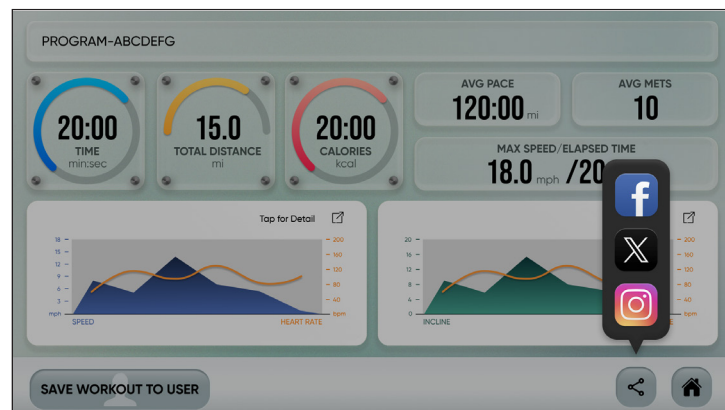
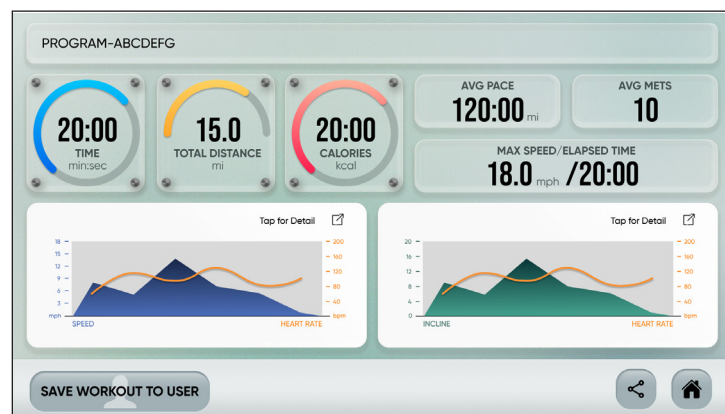
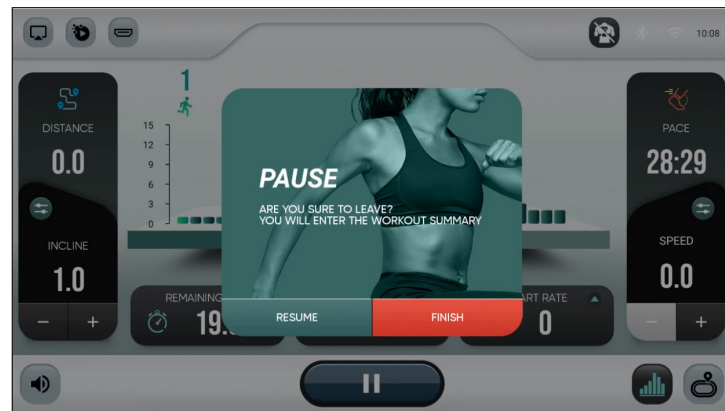

CONSOLE FEATURES

FEATURES OVERVIEW







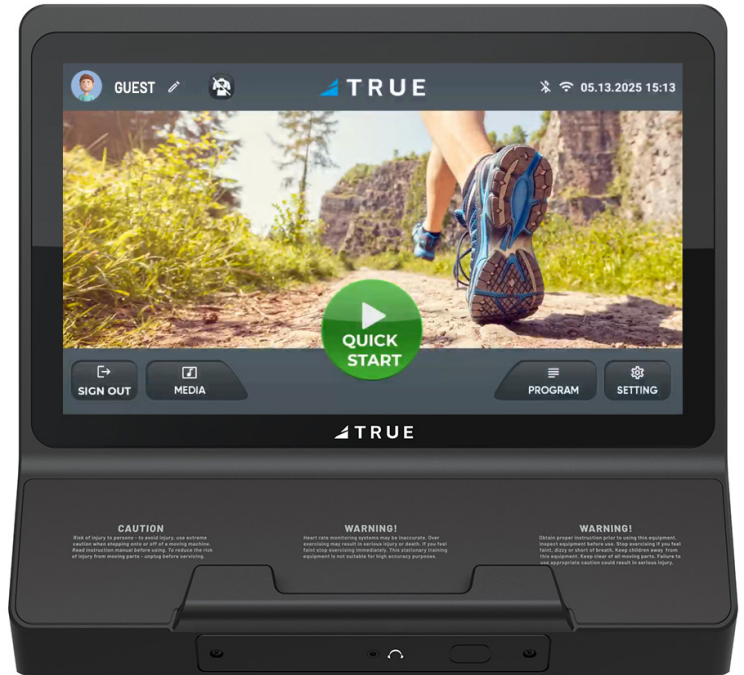

























































The TRUE 10", 16", and 22" touchscreen consoles offer a library of engaging workouts and options, allowing users to stay connected while staying focused on their fitness goals. These user friendly, easy to navigate consoles are compatible with the TRUE Performance Series Residential Treadmills.

Features:





























































- Consoles are available in the following screen sizes:
 - 10" (10.1 inches: resolution 1280 x 800)
 - 16" (15.6 inches: resolution 1920 x 1080)
 - 22" (21.5 inches: resolution 1920 x 1080)
- Touchscreen is multi-point capacitive touch
- Android OS
- Software updates can be done via the network (OTA) or by USB
- Bluetooth BT/BLE and Wi-Fi compatible
- FTMS compatible (GymTrakr, Zwift, Kinomap, and more)
- User's choice of Metric or Imperial units displayed on console
- User's choice for language displayed on console
- Mirroring from iOS or Android smart phone
- HDMI in (supports streaming devices like Roku and Fire Stick) / SD card expansion
- Heart rate detection supports contact heart rate grip, 5kHz wireless, and Bluetooth
- Backend membership management and personal exercise data cloud storage
- Virtual runs
- Third party entertainment and media apps



ICON DESCRIPTIONS

ICON	DESCRIPTION	ICON	DESCRIPTION	ICON	DESCRIPTION	ICON	DESCRIPTION
	Home		Minus		Sleep Mode		Heart Rate
	Close		Start		Child Lock		Distance
	Check		Pause		Connection		Pace
	Return		Switch		App Update		Steps
	Enter		Quick Setup		Refresh		Speed Run
	Enter		Quick Start		Auto Login		Incline Run
	Custom		Sign In		Display Mode		Repetition
	Enlarge		Sign Out		Machine Info		Ratio
	Down		Media		Machine Setting		Time
	Up		Program		Mirror		Time Auto Set
	Arrow Down		Setting		iOS		Time Not Set
	Arrow Up		On		Android		Time Set
	Arrow Left		Off		Draw		Rest Speed
	Arrow Right		Screen Brightness		Incline		Rest Time
	Next		Volume		Speed		Workout Profile View
	Plus		Beep Mode		Calories		Laps View

ICON DESCRIPTIONS

ICON	DESCRIPTION	ICON	DESCRIPTION	ICON	DESCRIPTION	ICON	DESCRIPTION
	Shrink Screen		Bluetooth		Password		Marine Corps
	Full Screen		Bluetooth Off		Birthday		Navy
	Quit		Wi-Fi		User		PEB
	Minimize		Wi-Fi Off		Age		Gerkin
	Application		Wearables Off		Height		Warning
	Facebook		Connect		Weight		Failed
	Instagram		Disconnect		Classics		Passed
	Twitter		Connect		H.R.C.		Total Distance
	Netflix		Disconnect		Interval		Total Time
	Disney		Connected		Marathon		Share
	Prime Video		Disconnected		Vision Run		Save Workout to App
	Youtube		Delete		User Program		Save Workout to User
	Spotify		Edit or Change		Fitness Test		
	HDMI		Account Data		Airforce		
	Scan		Personal Info		Army		
	Avatar		Mail		Coast Guard		

WORKOUT PROGRAM DESCRIPTIONS

Quick Start

Allows the user to start exercising immediately. A Quick Start workout is an open-ended workout with speed and incline adjustments controlled by the user. The default speed is 1.0 mph with a 0 incline setting. Each column of the workout profile is 1 minute long, and the workout values count up. There is no Warm Up or Cool Down for this workout.

Classics

The user can choose from the following classic programs: Goal, Hill, or Random Incline.

- Classics Goal Workout:** For a Classics Goal Workout, there are 3 adjustable Goals available, Time (default is 20 minutes), Distance (default is 5 miles), or Calories (default is 200 kcal). A user can choose 1 to 3 of the Goals, and adjust them. The values for Goals will count down toward zero during the workout. All other values will count up. When a Goal is achieved, the workout ends. There is no Warm Up or Cool Down for this workout.
- Classics Hill Workout:** This workout has three hills. With the largest in the final third of the workout. And using the maximum speed setting, speed will peak near the middle of the workout, allowing for a progressive build up and then a gradual decline. For a Classics Hill Workout, there is 1 adjustable Goal available, Time (default is 20 minutes), and there are 2 maximum workout settings, Maximum Speed (default is 2.0 mph) and Maximum Incline (default is 12%). The Goal value will count down toward zero during the workout. All other values will count up. When the Goal is achieved, the workout ends. There is a Warm Up and Cool Down for this workout.
- Classics Random Incline Workout:** Using the maximum incline setting, an incline profile is created randomly so every workout is different than the last. For a Classics Random Incline Workout, there is 1 adjustable Goal available, Time (default is 20 minutes), and 1 maximum workout setting, Maximum Incline (default is 10%). Based on the maximum incline setting, an incline workout profile is created. From the Preview Profile screen, tap on the refresh profile button for another random incline profile. The Goal value will count down toward zero during the workout. There is a Warm Up and Cool Down for this workout.

NOTE: The images below may differ from your console.

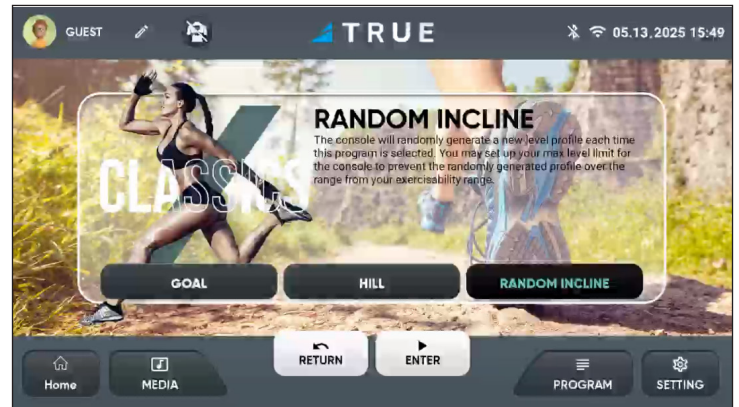
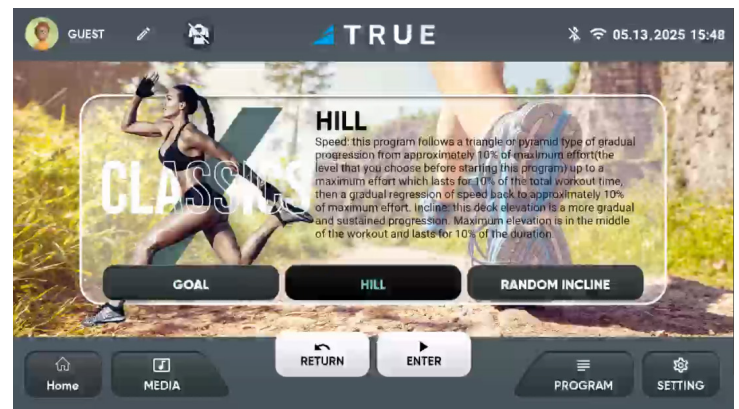
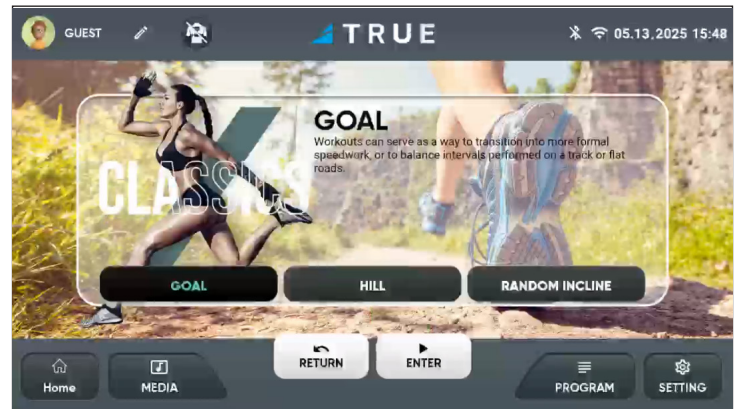
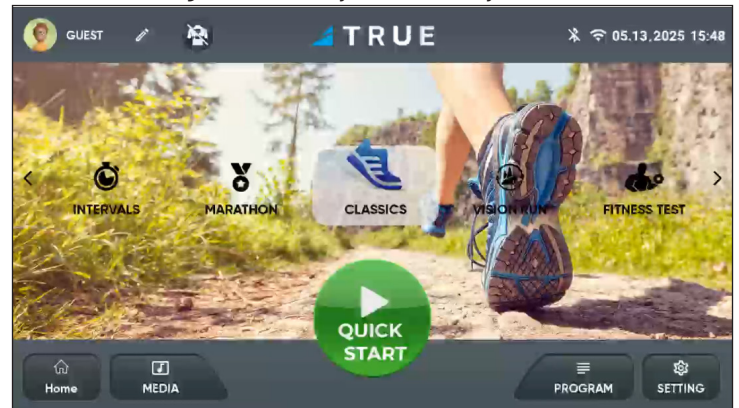

WORKOUT PROGRAM DESCRIPTIONS CONTINUED

Interval

The user can choose from the following programs: Speed, HIIT (High Intensity Interval Training), or Custom Intervals.

- Speed Workout:** Input the time for the workout and maximum speed, and a workout with 15 intervals, each with a Work and Rest segment, is created. Adjust the speed setting for each segment as needed. For an Intervals Speed Workout, there is 1 adjustable Goal available, Time (default is 20 minutes), and 1 workout setting, Maximum Speed (default is 2.0 mph). The value for the Goal will count down toward zero during the workout. All other values will count up. When the Goal is achieved, the workout ends. There is a Warm Up or Cool Down for this workout.
- Intervals HIIT Workout:** Set the speed for the Work segment of the interval, decide how many, and select the ratio of Work to Rest speeds, and get ready for an intense workout. For an Intervals HIIT Workout, there are 4 workout settings, Interval Ratio (default is 10:30 seconds, Work:Rest), Work Speed (default is 6 mph), Rest Speed (default is 2.0 mph), and Repetition (default is 10). The Repetition value is the number of intervals of the workout. Each interval has a Rest segment followed by a Work segment. All workout values count up except Time, which counts down to the end of that segment of the Interval. When the last interval is completed, the workout ends. There is a Warm Up and Cool Down for this workout.
- Intervals Custom Workout:** An interval workout designed by you specifically for you. Fully customize your interval workout by defining the time for the Work and Rest segments, the speed of each segment, and the total number of intervals. For an Intervals Custom Workout, there are 5 workout variables, Work Time (default is 1:00 minute), Work Speed (default is 6 mph), Rest Time (default is 0:30 seconds), Rest Speed (default is 2.0 mph), and Repetition (default is 4). The Repetition value is the number of intervals of the workout. Each interval has a Rest segment followed by a Work segment. All workout values count up except Time, which counts down to the end of the Rest or Work segment of the Interval. When the last interval is completed, the workout ends. There is a Warm Up and Cool Down for this workout. All Interval workouts use changes in speed between the Work and Rest segments of the intervals. Incline is not used, but can be adjusted throughout an Interval workout by the user.

NOTE: The images below may differ from your console.

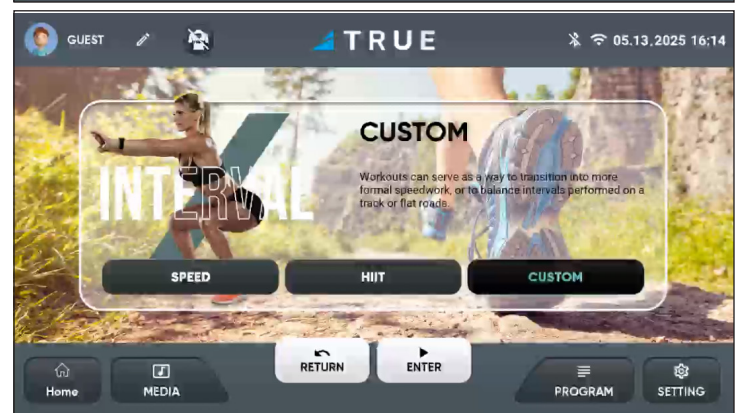
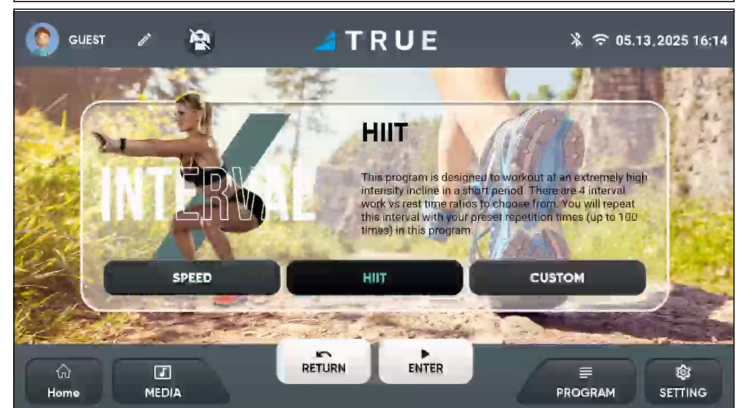
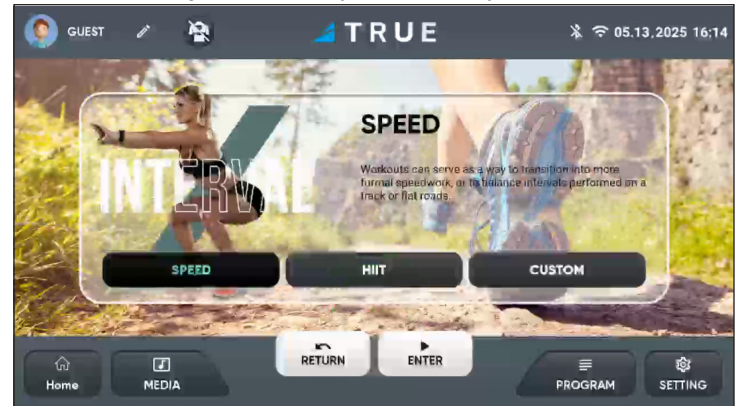

WORKOUT PROGRAM DESCRIPTIONS CONTINUED

Marathon

Choose from four preset distances: 5K, 10K, 21.5K, 42K. For a Marathon Workout, there is 1 workout defined Goal, Distance, and 1 adjustable Goal, Time (default is 20 minutes). A workout setting is also provided, Speed (default is 1 mph). The values for the Goals will count down toward zero during the workout. All other values will count up. When the Goal is achieved, the workout ends. There is no Warm Up or Cool Down for this workout. The distances in miles for each of the workouts: 5K (3.1 miles), 10K (6.2 miles), 21.5K (13.1 miles), and 42K (26.1 miles).

NOTE: The images below may differ from your console.

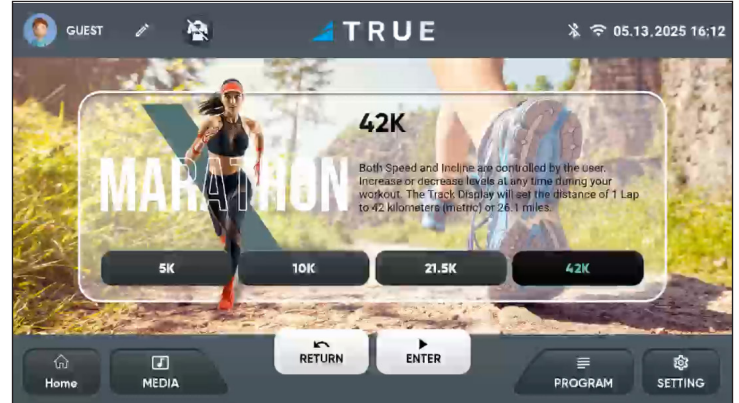
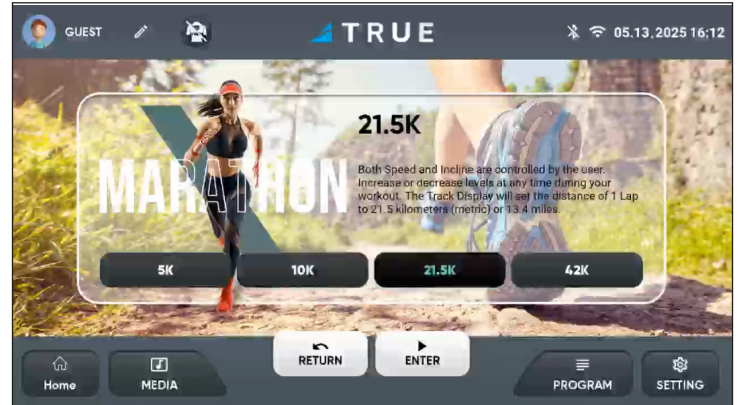
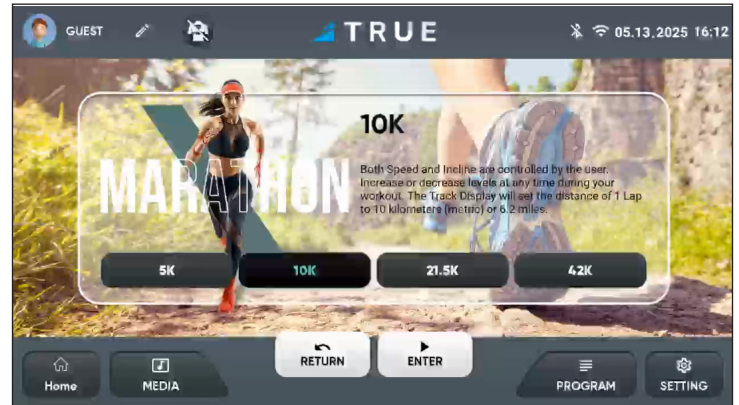
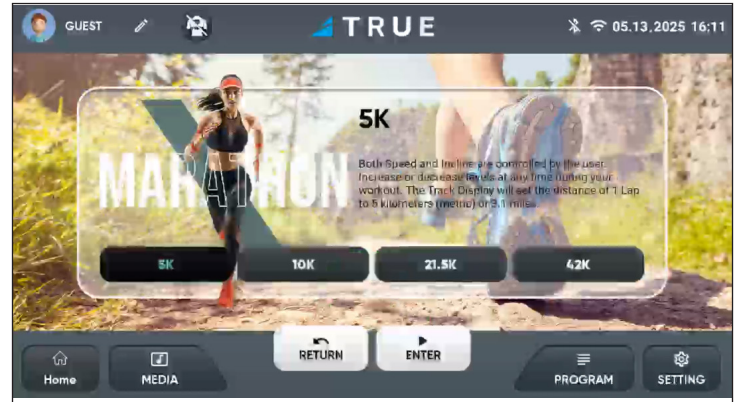

WORKOUT PROGRAM DESCRIPTIONS CONTINUED

User Program

A user can choose to repeat a previously saved workout or can create a new customized workout with a simple swipe of a finger. Once created, it can easily be selected for your next workout. If signed in, the last 10 saved Custom Workouts for that Profile are displayed across the top of the screen. If signed in as a Guest user, the last 10 saved Custom Workouts by any Profile are displayed across the top of the screen. Press a Custom Workout, and the details of the saved Custom Workout are displayed. To begin the selected workout, press Start. If a more focused workout is desired, then create your own Custom Workout.

To create a Custom Workout, press Custom. The screen will display a blank speed profile. Slide your finger across the display defining the peak speed levels for the workout. The screen captures the motion, and fills in the speed profile. To adjust a specific column of the profile, hold your finger on it and then slide your finger up or down to the desired setting. Press Next, and the screen will display the blank incline profile. Slide your finger across the display defining the peak incline levels for the workout. If necessary, adjust the incline profile and then press Next.

The screen will display the 1 adjustable Goal available, Time (default is 20 minutes), and the 1 workout setting, Maximum Speed (captured by the highest value of the speed profile). Adjust the Time value, and press Next. The screen will show a preview of the Workout Profile for Incline and Speed. To begin the Custom workout, press Start. During the workout, the value for the Goal will count down toward zero. All other values will count up. When the Goal is achieved, the workout ends. There is no Warm Up or Cool Down for this workout.

NOTE: The images below may differ from your console.



WORKOUT PROGRAM DESCRIPTIONS CONTINUED

Vision Run

In virtual reality mode, the user can exercise while watching videos of scenic routes. For each Vision Run Workout, there are 3 adjustable Goals available, Time (default is 20 minutes), Distance (default is 5 miles), or Calories (default is 200 kcal). A user can choose 1 to 3 of the Goals, and adjust them. The values for Goals will count down toward zero during the workout. All other values will count up. When a Goal is achieved, the workout ends. There is no Warm Up or Cool Down for this workout. The speed of the video playback is directly related to the speed of the belt, and will adjust with changes.

The incline of the deck is not reflected in the video. Applications and Mirroring are disabled during a Vision Run Workout. Press **[F]** to go to full screen mode. Press **[Esc]** to go back to standard mode.

Fitness Test

These programs provide workouts of a preset distance, as required by the Air force, Army, Coast Guard, Marine Corps, Navy, and PEB. At the completion of the test, a time-based score (defined by the respective branch of the Military) is returned to the user.

The gerkin fitness test is a tiered VO2 test with sub-maximal values. It is used by the International Association of Fire Fighters to determine fitness for service with the fire department.

Be sure the height, gender, age, and weight are all correctly entered for your active profile. The Fitness Test is Pass or Fail, so be ready.

NOTE: The images below may differ from your console.

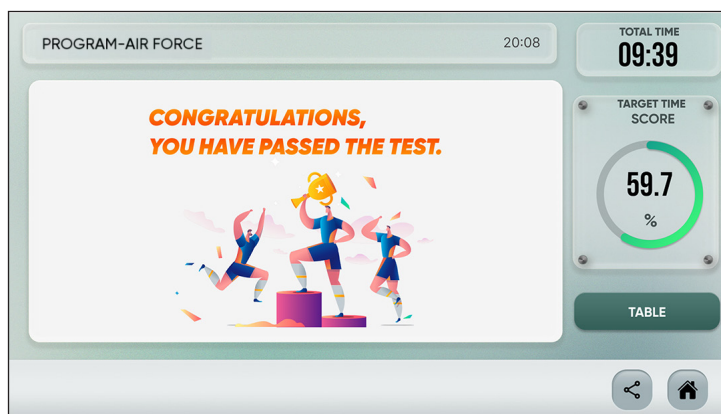
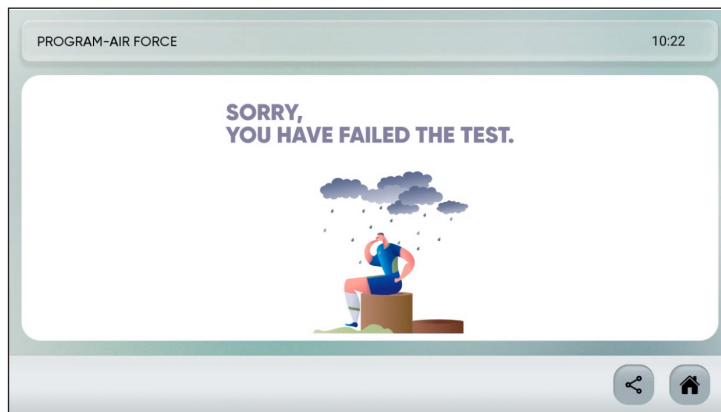
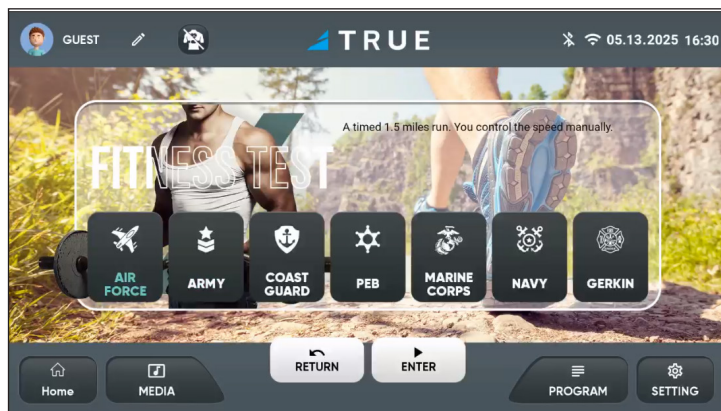
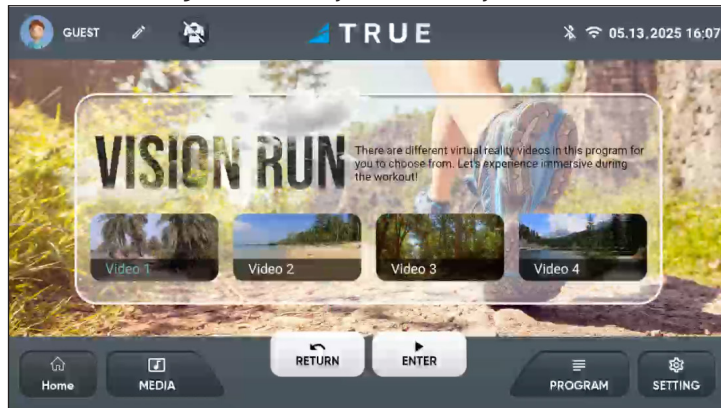

WORKOUT PROGRAM DESCRIPTIONS CONTINUED

TARGET H.R.C

There are three modes: 60%, 70%, and 80%. During a Heart Rate Control workout, speed is adjusted to keep you at your targeted heart rate.

The intensity of the workout is driven by your current heart rate. So be sure that your Heart Rate device works, the age in the profile is current, and the targeted heart rate is adjusted for you.

A Heart Rate device is required to perform a Heart Rate Control Workout. The goal of a Heart Rate Control Workout is for you to workout close to your target heart rate. If your heart rate is not close enough to the target rate, the treadmill will ask you to adjust the intensity of your workout. These adjustments can be to speed or incline. If your heart rate is still not close enough to the target rate, the treadmill will automatically adjust the speed of the running belt every 10 seconds.

For a Heart Rate Control Workout, there is 1 adjustable Goal available, Time (default is 20 minutes), and the Target Heart Rate (bpm). The default Target Heart Rate is calculated using the age of the active profile. Be sure that your age is entered correctly for the active Profile. The value for the Goal will count down toward zero during the workout. All other values will count up (excluding Heart Rate). When the Goal is achieved, the workout ends.

Target Heart Rate = $220 - (\text{your age}) * (\text{the selected \% value of the workout})$.

If the console has reduced the speed to the minimum and your heart rate is +25 bpm above your maximum heart rate, the Heart Rate is too High / STOP screen will be displayed. Safely end your workout immediately. If the workout does not end after 30 seconds, and your heart rate has not reduced, the workout will be ended.

During a Heart Rate Control workout, if the signal from the hear rate device is lost for 15 seconds, the Reconnect or End the Program screen will be displayed. If the heart rate device does not reconnect after 30 seconds, the workout will be ended.

NOTE: If your Heart Rate wearable device seems to be working properly but the console has lost the connection, restart it. This may re-establish the signal between the devices.

NOTE: A Polar® Chest Strap is included with your Performance Series Treadmill. The console should automatically detect and connect to this chest strap.

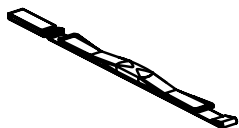

NOTE: The images below may differ from your console.

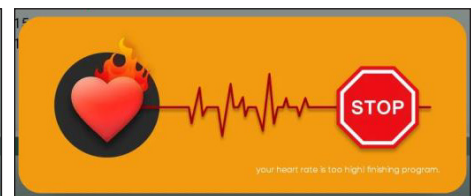
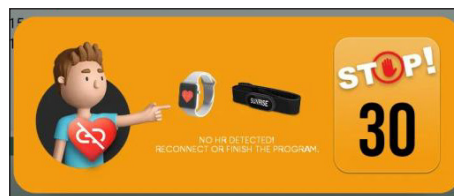
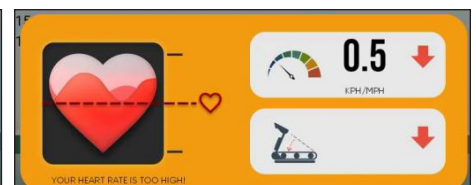
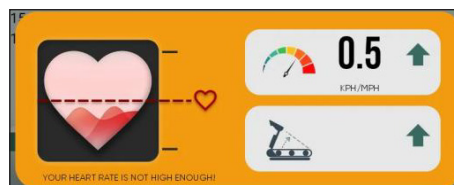
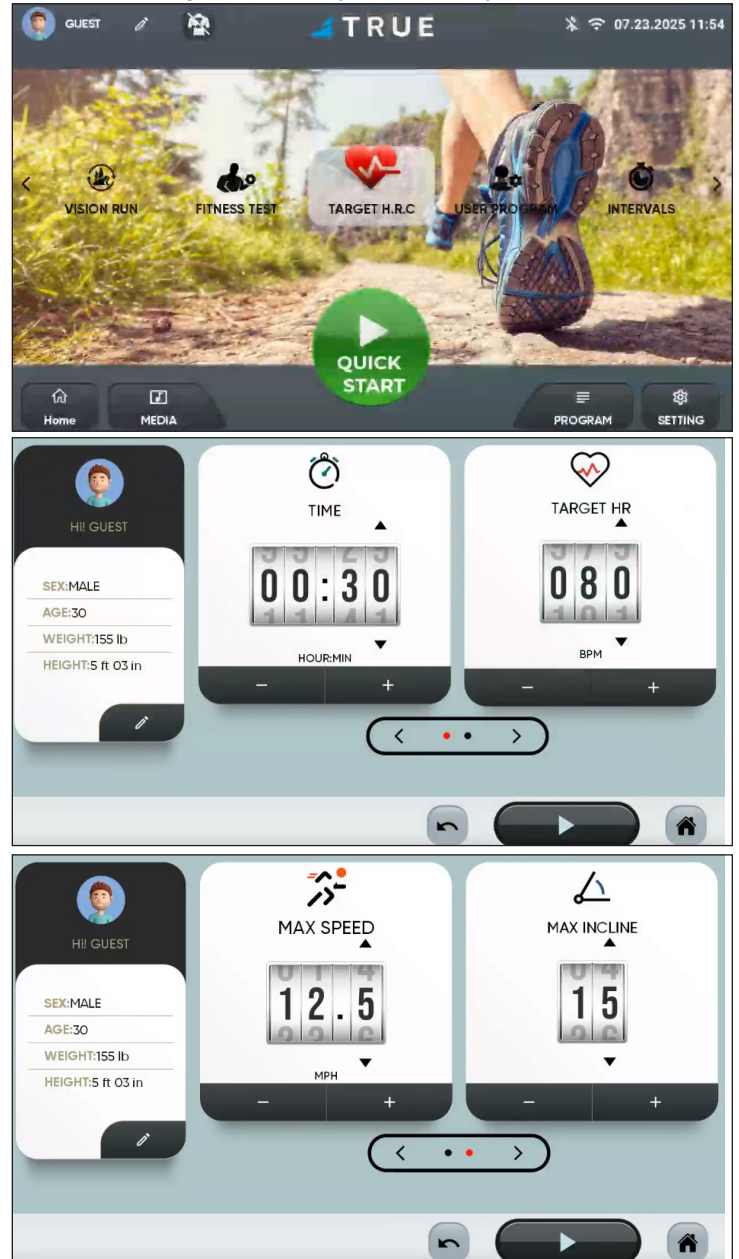

HEART RATE MONITORING

Bluetooth transmitters and chest straps transmit the user's heart rate to the machine via radio, and the CHR pads connect to a special computer circuit to extract the user's heart rate.

Chest Strap and Bluetooth Heart Rate Monitoring

Although this cardio equipment functions fine without using the heart rate monitoring feature, this kind of monitoring gives valuable feedback on the user's effort level. Using a chest strap or Bluetooth monitoring also allows users to use Heart Rate Control, the most advanced exercise control system available. When users wear a Polar® compatible transmitter strap or a Bluetooth transmitter, the machine will display the user's heart rate as a digital beats-per-minute (bpm) readout. A chest strap should be worn directly against the user's skin, about 1-2 inches below the pectoral muscles/breast line. Women should be careful to place the transmitter below their bra line. Bluetooth transmitters should be worn in accordance with the manufacturer's documentation. Initially the transmission signal for heart rate may be erratic or non-existent. Some moisture is necessary between the strap and the user's skin for proper transmission. Sweat from exercise works best, but ordinary tap water may be used prior to the workout if desired.

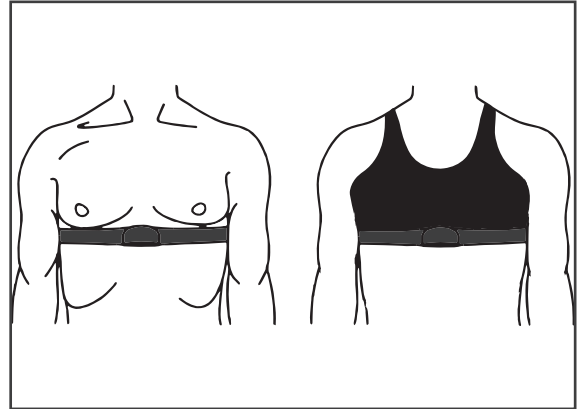

NOTE: The chest strap produces a radio signal that the console reads and registers as the user's heart rate. The accuracy of a reading may be affected when outside interference is present.

Contact Heart Rate (CHR)

The CHR system will let the user monitor their heart rate without wearing a chest strap. When using the CHR system users should gently grasp the CHR pads with both hands. Within 30 seconds, the user's heart rate should be displayed as a digital bpm readout (during the first 30 seconds the system is analyzing and locking in the user's heart rate). Users should exercise with smooth body motions and breathe regularly. It is best to avoid talking while using the CHR system, as talking will cause unrepresentative heart rate spikes of 5 to 10 bpm. To ensure an accurate reading, the user's hands should be clean, free of both dirt and hand lotions.

NOTE: For increased safety and accuracy the CHR system should only be used at speeds of 4 mph or lower (CHR readings are less accurate due to large muscle movements above this speed).

NOTE: CHR monitoring may be less accurate than chest strap monitoring since the heart rate signals are much stronger at the chest. When using a HRC workout, it is best to use a chest strap because of the stronger and more accurate readings. Do not use the contact heart rate grips as a handlebar during a workout.

⚠ CAUTION: Do not use the contact heart rate grips as a handlebar during a workout.

Target Heart Rate

Heart Rate Control (H.R.C) workouts let the machine monitor relative exercise intensity by way of the user's heart rate, then will tell you to adjust the speed, incline, and resistance to keep the user at their target heart rate and thus their desired exercise intensity. Heart rate is a good measure of the body's exercise stress level. It reflects differences in physical condition, fatigue, the comfort of the workout environment, even diet and emotional state. Users should compare their heart rate with how they feel to ensure safety and comfort.

Consult a Physician to Determine Heart Rate

Using heart rate to control a workout takes the guesswork out of the workout settings. Consult a physician before using heart rate controlled workouts for advice on selecting a target heart rate range. Also, it is important to use the machine for several workouts in the manual mode while monitoring heart rate. Users should compare their heart rate with how they feel to ensure safety and comfort. After users have spent some time learning how their heart responds to different levels of speed, incline, and resistance, they will have a better understanding of how to select the maximum speed and maximum incline required for reaching their target heart rate.

CONSOLE NAVIGATION

HOME SCREEN

The home screen is displayed on the console when there is no workout in progress. From this screen the user is able to select from various options to begin a workout.

NOTE: The image shown may differ from your console.

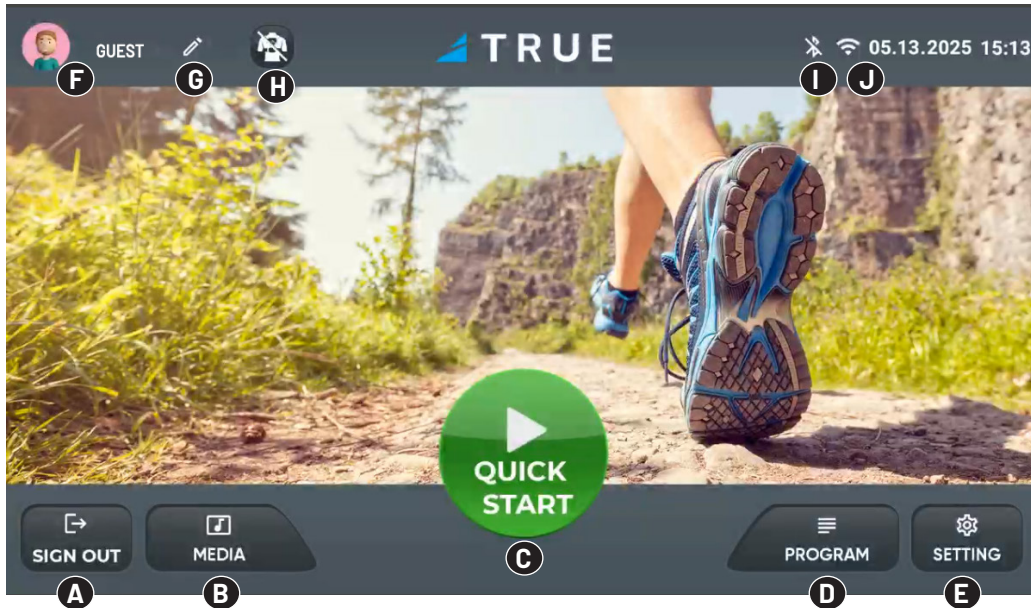

A. Sign In / Sign Out

The user can sign in to an existing account, sign up for a new account, or skip and choose to sign in as a guest. If there is not an internet connection, the user cannot sign in or sign up, but can continue as a guest.

B. Media

Allows the user to display apps, mirror from their device, or display content from an HDMI connection. If there is not an internet connection, the user will not be able to use certain apps.

C. Quick Start

Allows the user to start exercising immediately. The user manually adjusts speed and incline and must press pause to stop the workout.

D. Program

Allows the user to access the workout programs available on the console.

E. Setting

Allows the user to access connection settings, machine settings, app updates, and machine information.

F. User Profile

Current active user profile.

G. Edit Profile

Edit or create a profile that stores a user's account data and personal information.

H. Wearable

Allows you to connect to a compatible device.





I. Bluetooth

Bluetooth connected or disconnected indicator.

J. Wi-Fi

Internet connected or disconnected indicator. Pressing the icon opens the Wi-Fi screen and allows you to select from the available Wi-Fi connections and view Wi-Fi setting information.

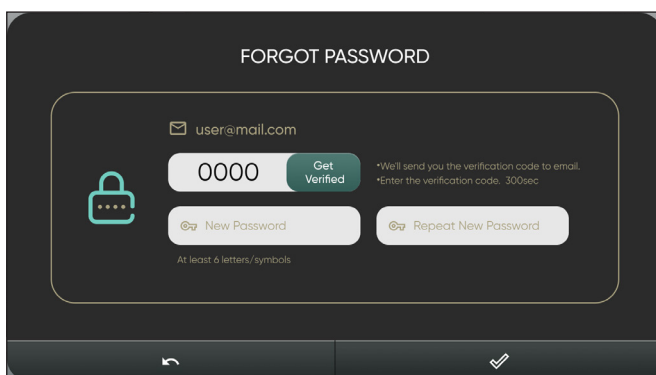
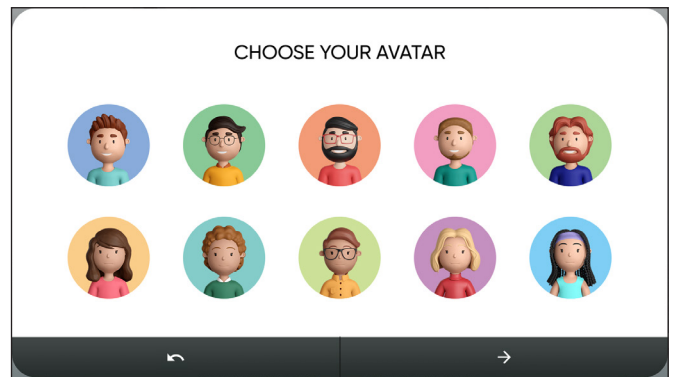
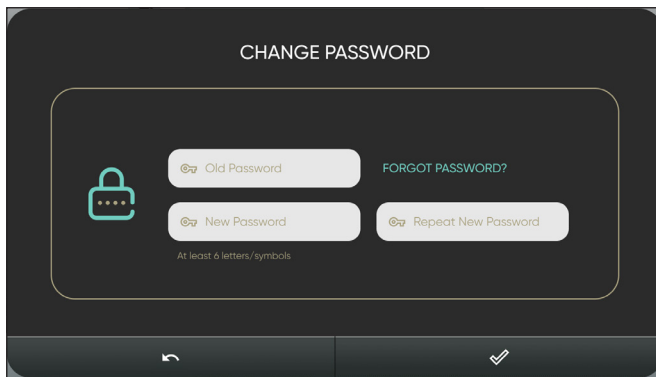
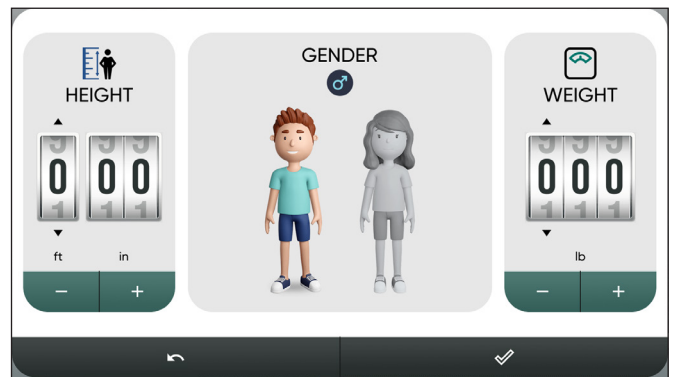
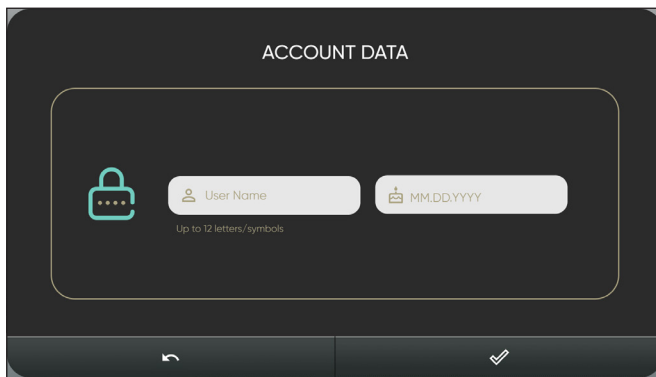
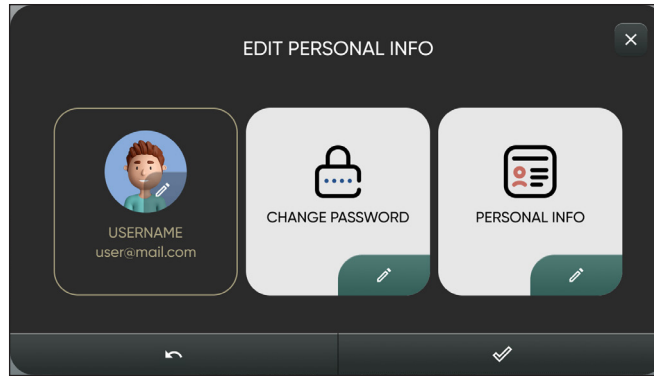

USER PROFILES AND PERSONALIZATION

To modify a user profile, press edit  on the home screen. On the **EDIT PERSONAL INFO** screen, press edit  on the information you want to change. Press confirm  to save the changes. Press return  to exit back to the home screen.



APPLICATIONS

NOTE: The images shown may differ from your console.

To access an application press **MEDIA** , press **Application** , and then press the desired application, log into your account, and enjoy it on your console.

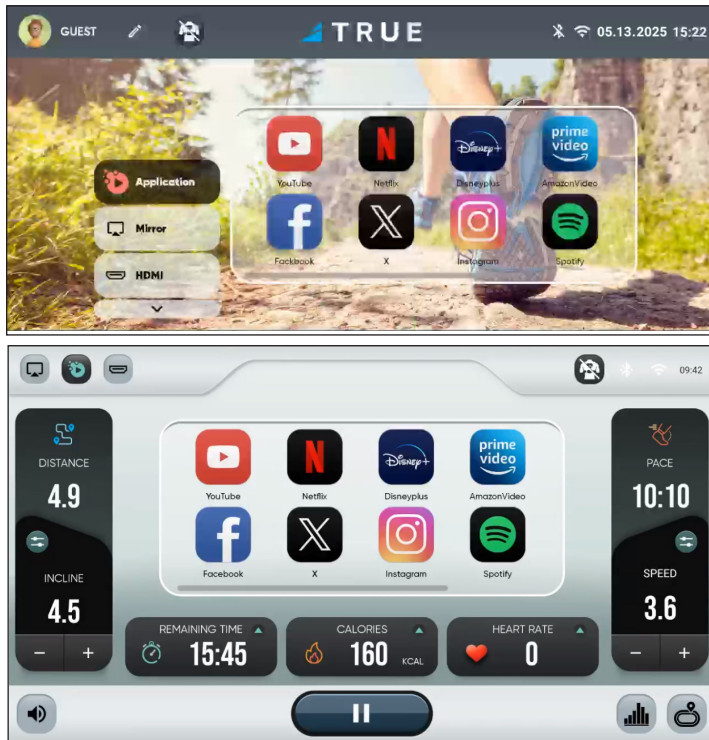

Applications can be viewed in the standard screen mode, where the application is displayed along with the treadmill information, or in full screen mode, where the application fully covers the display.

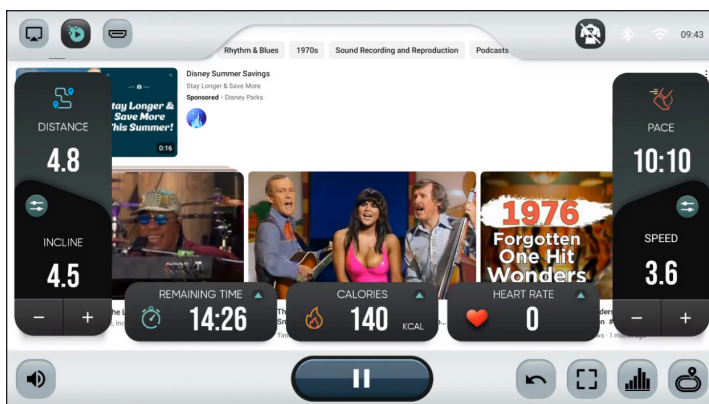



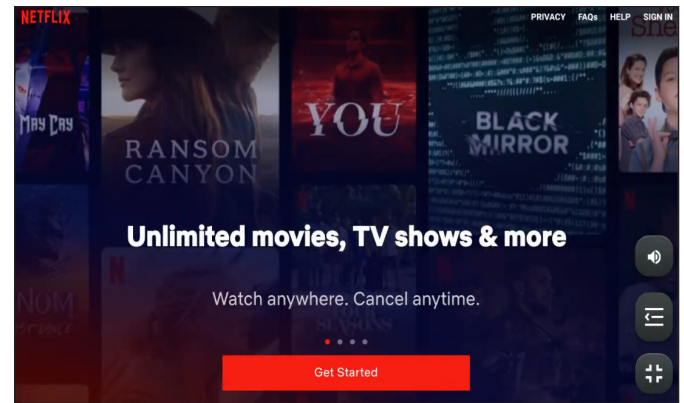

Press  to shift to full screen mode.

Press  to shift from full screen mode to standard screen mode.

Application in full screen mode in a workout.



In full screen mode you can use the controls on the lower right side (, , ) to adjust the volume, view distance, change incline and speed, or press pause. Press the quit icon () to leave the app and return to the regular workout screen.

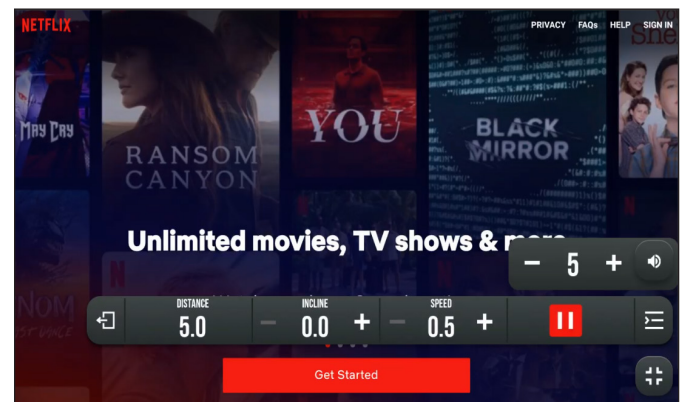



MIRRORING

NOTE: The images shown may differ from your console.

Mirroring allows the screen of your device to be projected onto the console display. Depending on your type of device, iOS or Android, will decide how you activate the screen projection.

NOTE: The console and your device must be connected to the same Wi-Fi.

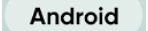
To access mirroring press **MEDIA** , press **Mirror** , and then depending on your device, press **iOS**  or **Android** .

Follow the instructions shown on the console and your device. To stop mirroring, press "Stop Mirroring" from the device.

iOS devices: With the connected Wi-Fi matching on the iOS device and the console, press **Screen Mirroring** on the device. Select the console, **Device-XXX**, from the Screen Mirroring list, and then press **Start Mirroring**. The console will show the screen of the device.



Android devices: Be sure that the Android device and the console are connected to the same Wi-Fi. Scan the provided QR code on the screen, or search for the **ANPLUS Screen Mirroring** app in the Google Play Store and install it. Open the app and press **Start Searching**. Select the console, **Device-XXX**, from the list, and then press **Start Mirroring**. The console will show the screen of the device.



HDMI

NOTE: The images shown may differ from your console.

From the home screen, tap **MEDIA** and select **HDMI**. Once a computer or other device is connected via the HDMI port, the HDMI function will activate.

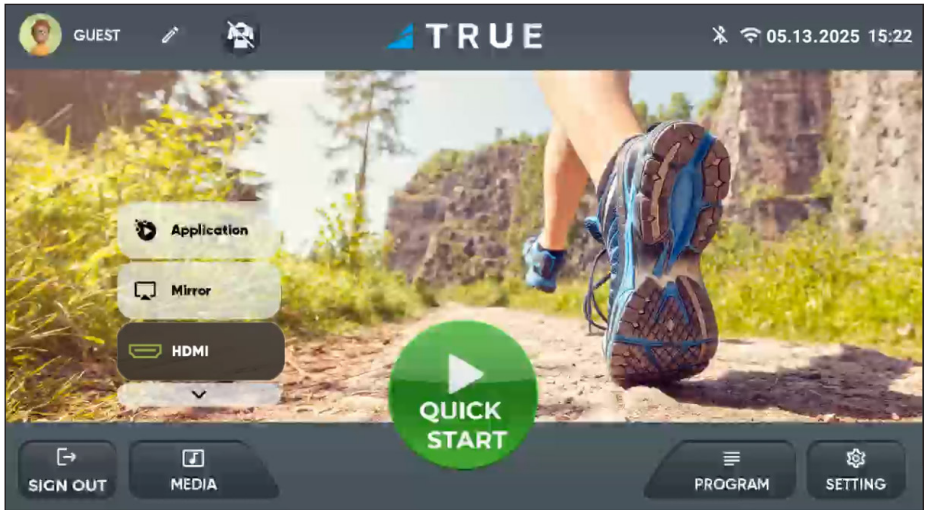

MACHINE SETTINGS

To access machine settings press **SETTING**  and then press **Machine Setting** .

 **SCREEN BRIGHTNESS:** Adjust the slider left to decrease or right to increase the SCREEN BRIGHTNESS.

 **VOLUME:** Adjust the slider left to decrease or right to increase the Volume.

TIME AND DATE: Time has two settings which can be customized: 24 HOUR or AUTO SET. The 24 HOUR setting allows the time to be either set to 24 hours (ON) or 12 hours, AM or PM (OFF). With AUTO SET turned off, the Time and Date can be modified. To modify a value, tap and hold on the digit that you want to modify and slide your finger up (+) or down (-) until it is the desired value. To modify the Date, the AUTO SET must be set to OFF.

LANGUAGE: To view the available languages for the console, press LANGUAGE. To change to one of the available languages, press the desired language. The console shifts to the selected language.

UNIT: To change the units of measurement, press UNIT. The option for IMPERIAL or METRIC is displayed. Press the desired unit of measurement.

 **DISPLAY MODE:** (ON) Remove the security key and the screen will not close. (OFF) Remove the security key and the screen will turn off.

 **SLEEP MODE:** (ON) If there is no input for thirty minutes while on the Home or Idle screen, the machine will go into SLEEP MODE and turn off the display. Push any button to activate the display. (OFF) The displays stays on.

 **AUTO LOGIN:** (ON) Provides an option on the SIGN IN screen for a user to select **Log me in automatically**.

 **CHILD LOCK:** (OFF) When Child Lock is on, if there is no input for ten minutes while on the Home or Idle screen, the machine will lock itself. A "CONSOLE LOCKED" screen is displayed. Push and hold the Stop button for three seconds to unlock the machine. Once locked, the machine must be unlocked with the Stop button. If the power is turned off and the machine restarted, it will be in locked mode.



 **BEEP MODE:** (ON) Turns on/off the sound made when a button is pushed.

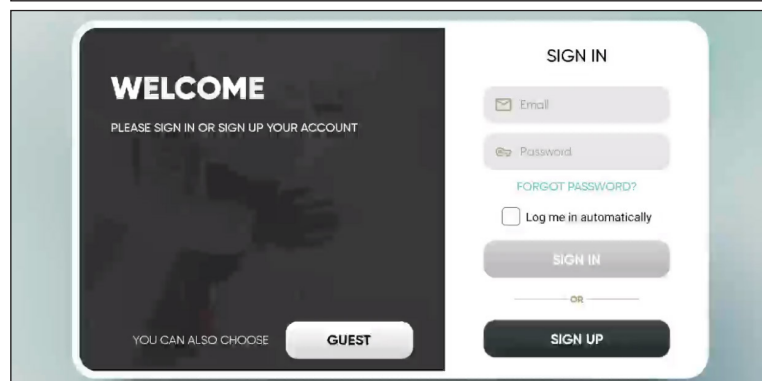
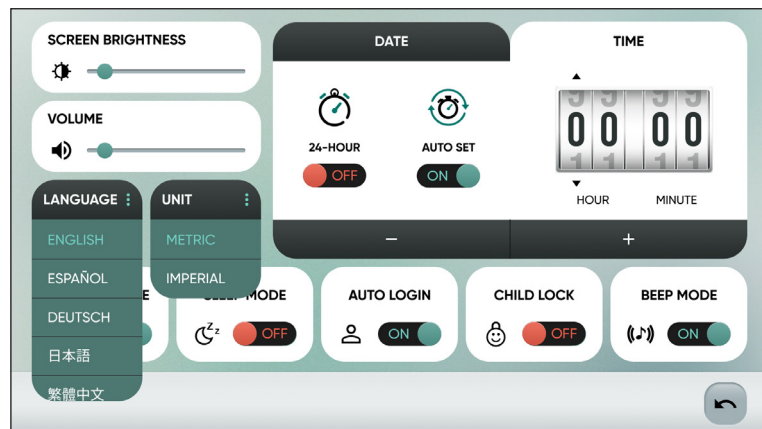
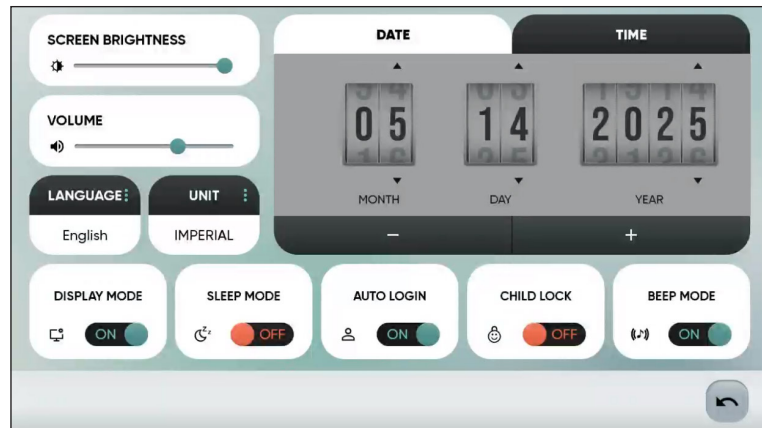

 **RETURN:** Returns to the previous screen.

NOTE: The images below may differ from your console.



APP UPDATES

To access app updates press **SETTING**  and then press **App Update** .

If there is an update-able app, the **Update** button  will be highlighted, otherwise it will be disabled .

When an update is available and you push **Update**, the button changes to reflect the download/install status of the update. When the app is done updating, the button becomes disabled again.

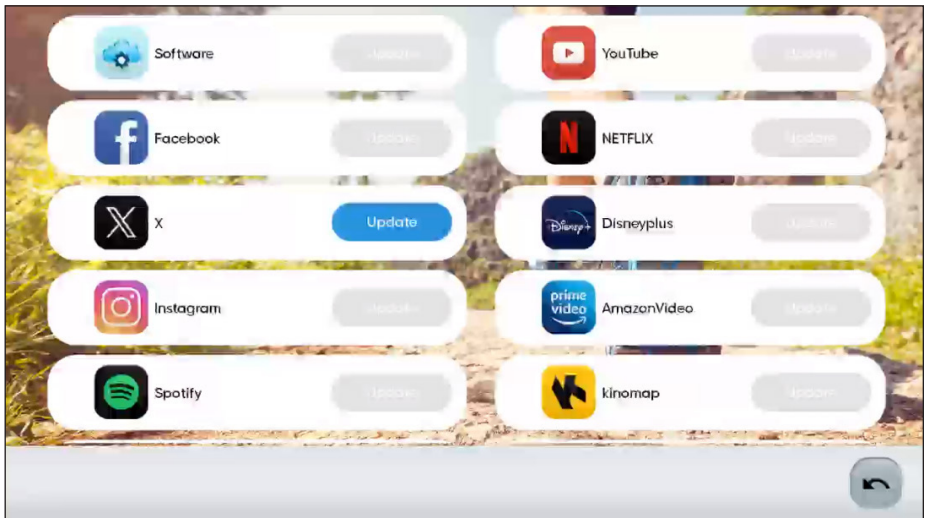
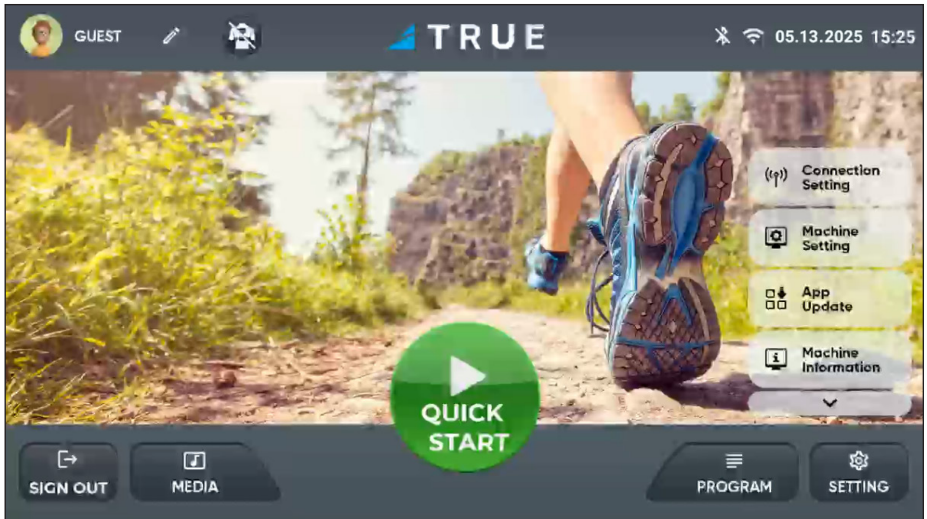

Press **return**  to go back to the home screen.

NOTE: The images below may differ from your console.



MACHINE INFORMATION

To access machine information press

SETTING  and then press **Machine Information** .

SOFTWARE VERSION: Shows the currently installed version of software.

HARDWARE VERSION: Shows the current configuration of hardware.

SYSTEM VERSION: Shows the current version of the system.

LC VERSION: Shows the current version of the Lower Control Board.

TOTAL TIME: Shows the accumulated hours that the treadmill has been used.

TOTAL DISTANCE: Shows the accumulated distance that the motor has been used (miles or kilometers).

 **RETURN:** Returns to the previous screen.

NOTE: The image below may differ from your console.

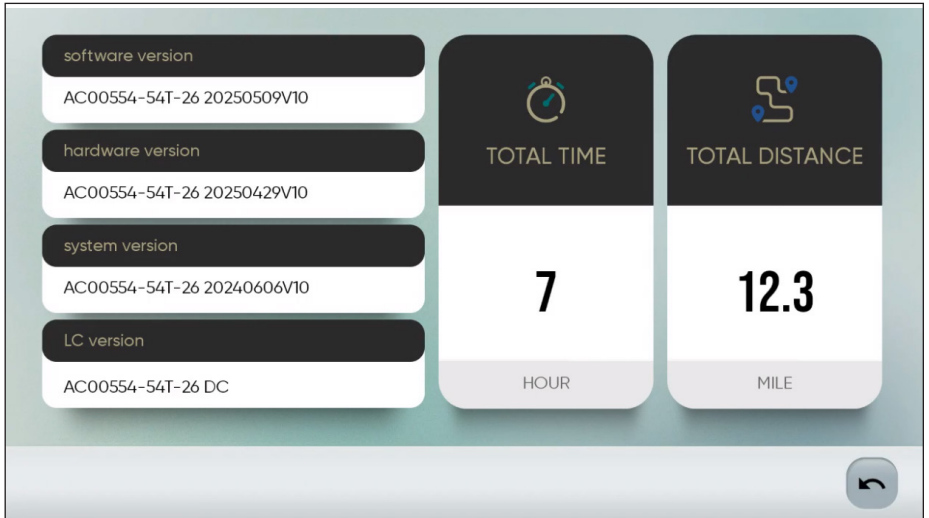

ADVANCED FUNCTIONS

To access advanced console functions, tap the TRUE logo  on the home screen 10 times.

NOTE: You should only access these screens if you've been instructed to do so by TRUE Product Support.

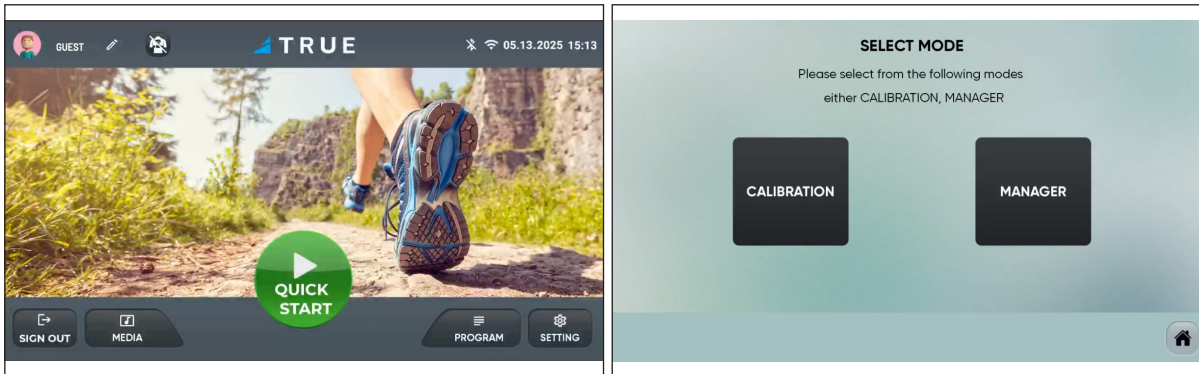

CALIBRATION

On the calibration screen, choose the correct base model the console is installed on: **TPS1000, TPS3000, or TPS8000.**

After choosing the correct base model, ensure the values are entered correctly for speed and incline.

If you need to change any of the values shown for speed or incline, tap the input field to open the keyboard.

After entering the desired value, press **ENTER** to confirm and close the keyboard.

If the entered value exceeds the allowed range, the system will automatically display the max or min value.

Item	Default Value	Settable Range
Max Speed	Metric: 16.0 kph Imperial: 10.0 mph	Metric: 16.0 ~ 20.1 kph Imperial: 10.0 ~ 12.5 mph
Min Speed	Metric: 1.0 kph Imperial: 0.5 mph	Metric: 0.5 ~ 2 kph Imperial: 0.3 ~ 1.2 mph
Max Incline	15	10-15

After the values for **Machine**, **Max Speed**, **Min Speed**, and **Max Incline** are entered correctly per the settable ranges, press **Start to Calibrate**.

⚠ WARNING: This process will take full control of the machine and can be dangerous if caution is not taken.

- Calibration can take up to two minutes to complete.
- Do not stand on the machine during the calibration procedure.
- Verify that the machine is free of all parts and tools.
- Keep children and animals at a safe distance.

Once calibration has been started, it is not possible to leave this mode until the process completes. The system will automatically exit after calibration is completed.

When the calibration is completed and successful, the system will retain the calibration parameters and return to the home screen.

Otherwise, the system will maintain the last calibration value and no changes will be made.

NOTE: The images below may differ from your console.

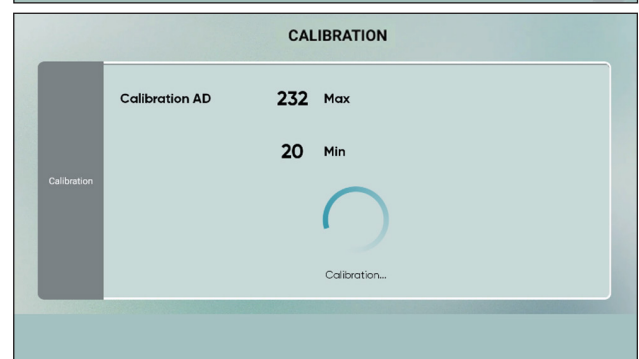
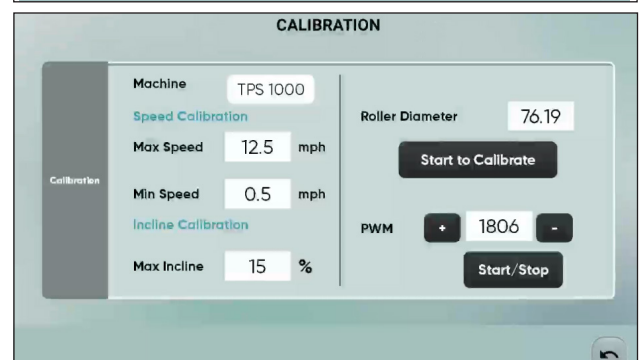
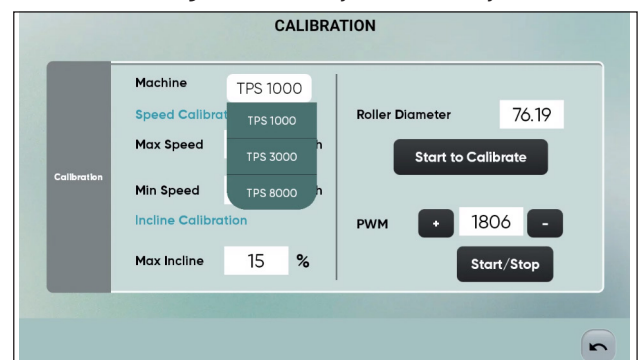

MANAGER

MANAGER mode is divided into five categories: **Setting, Information, Diagnostic, Update,** and **Logo.**

MANAGER → Setting

GS Mode: Is incline reset? Takes effect immediately after setting.

(Default=OFF) incline returns to 0 when console returns to home screen.

(ON) the incline does not return to zero and stays at its current position.

HDMI: (reserved) Turns display on/off.

(Default=OFF) In the media, the HDMI function keys are not displayed in all languages.

(ON) In the media, the HDMI function keys are displayed in all languages.

Lube: You can modify the desired distance by yourself, and a prompt window will appear when the distance returns to zero.

(Default =300 KM / 186 MILE)

After modification, press **RESET** to write the new setting value and take effect.

System Reset: Return to the state where you have finished brushing the img.

Password required.

Factory Reset: Clears total distance, total time, clears error codes, restores lube to default values, logs out of all third-party accounts, clears local login user mailbox, clears exercise records in user program.

No password is required.

 **RETURN:** Returns to the previous screen.

NOTE: The images shown may differ from your console.

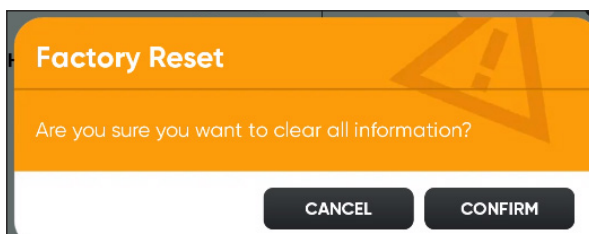
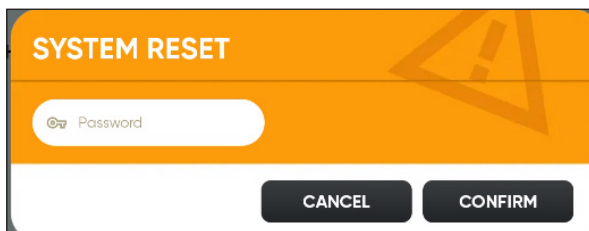
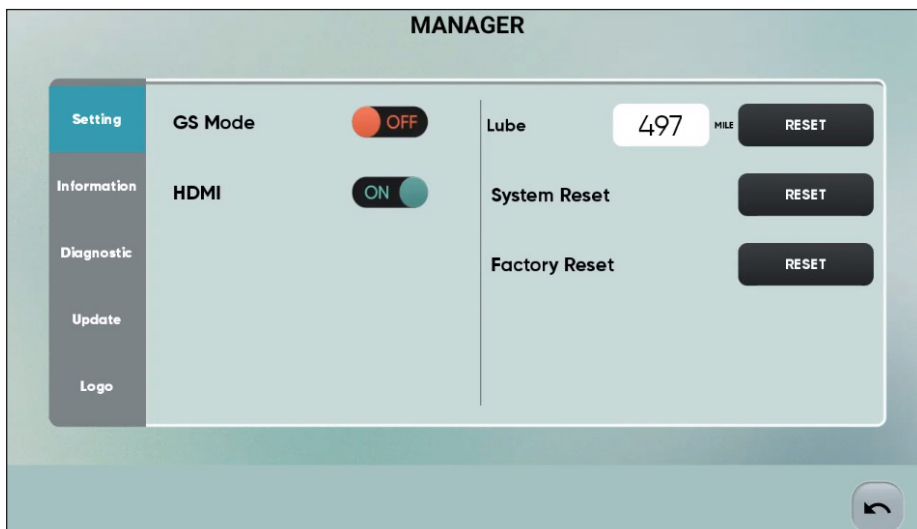

MANAGER → Information

Total Time: Displays the total accumulated usage time during exercise.

Total Distance: Displays the total accumulated mileage during exercise.

RESET: Clears total usage time and total usage mileage.

Software Ver.: Shows the currently installed version of software.

Firmware Ver.: Shows the current configuration of hardware.

Operating System Ver.: Shows the current version of the system.

Lower Control Ver.: Shows the current version of the Lower Control Board.

 **RETURN:** Returns to the previous screen.

NOTE: The images shown may differ from your console.

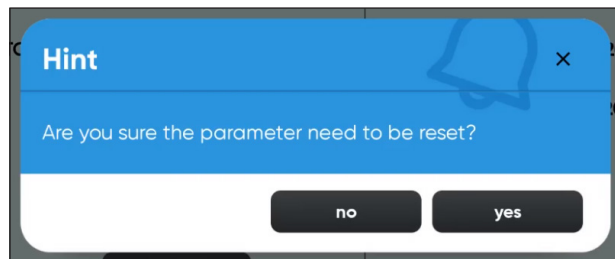

MANAGER → Diagnostics

Press **DESCRIPTION** for error code information and **HISTORY** for recent error code history.

Press return  to go back to the previous screen.

Press home  to go to the home screen.

NOTE: The images shown may differ from your console.

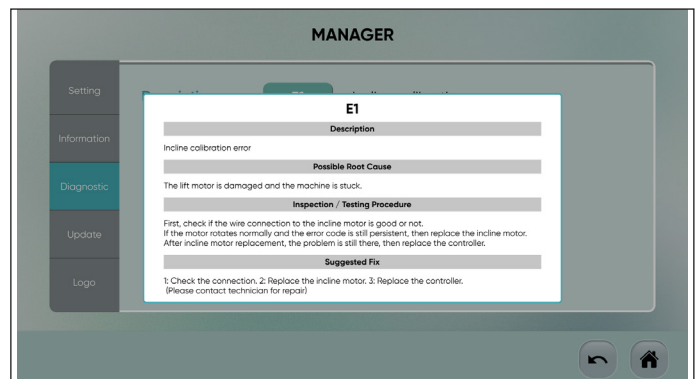
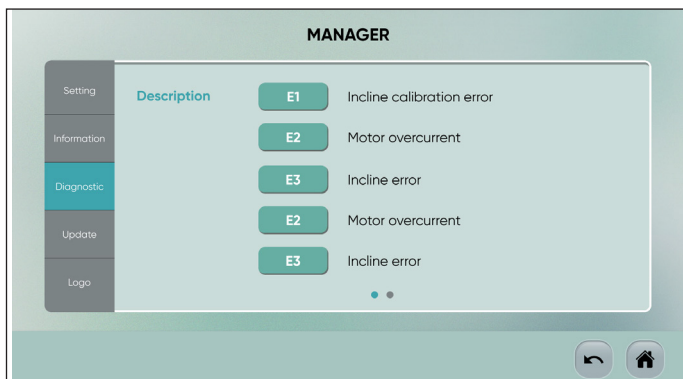
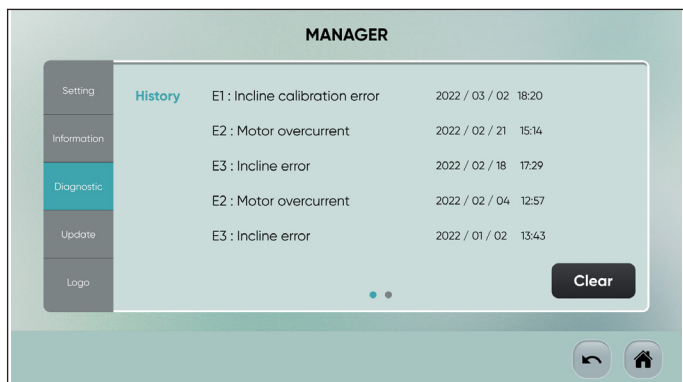
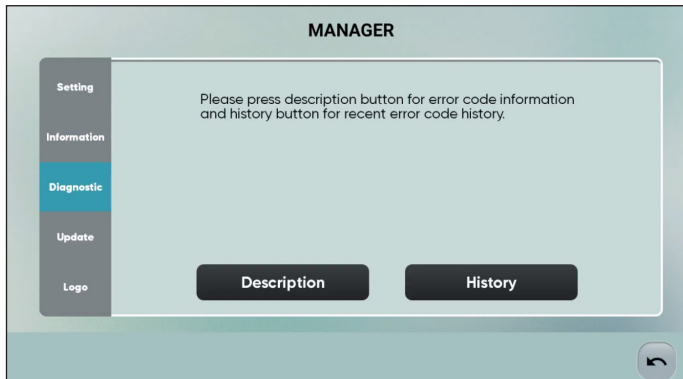

MANAGER→Diagnostics→ERROR DESCRIPTIONS

Error Code	Error Description	Corrective Action
E01	Overload	<ol style="list-style-type: none"> 1. May be caused by exceeding rated load, which leads to excessive current—system enters protection mode. Restart the machine. 2. A jammed part on the treadmill may prevent the motor from running, causing overload and high current. Adjust the treadmill or add lubricant, then restart. 3. Check if the motor produces overcurrent noise or burnt smell during operation. Replace the motor if necessary. 4. Replace the controller. 5. Contact product support.
E02	Hall Sensor Error	<ol style="list-style-type: none"> 1. Check the motor cable connection; reconnect if loose. 2. Replace the motor. 3. Replace the controller. 4. Contact product support.
E03	Hardware Overcurrent	<ol style="list-style-type: none"> 1. May be caused by excessive load and current—system enters protection mode. Restart the machine. 2. Check power plug and motor connections for looseness. 3. Replace the controller. 4. Contact product support.
E04	Phase Loss	<ol style="list-style-type: none"> 1. Check the motor cable connection; reconnect if loose. 2. Replace the motor. 3. Replace the controller. 4. Contact product support.
E05	Undervoltage	<ol style="list-style-type: none"> 1. Check if input voltage is normal. 2. Check the power plug connection for looseness. 3. Contact product support.
E06	Overvoltage	<ol style="list-style-type: none"> 1. Check if input voltage is normal. 2. Replace the controller. 3. Contact product support.
E08	Hardware Error	<ol style="list-style-type: none"> 1. Check power plug and motor connections for looseness. 2. Replace the controller. 3. Contact product support.
E16	Incline Adjustment Error	<ol style="list-style-type: none"> 1. Check if the incline motor cable is connected properly. 2. Reconnect and power cycle. 3. Reconnect and recalibrate. 4. Contact product support.
E17/ CALIBRATION FAIL	Incline Calibration Error	<ol style="list-style-type: none"> 1. Check if the incline motor cable is connected properly. 2. Reconnect and recalibrate. 3. Contact product support.
E21	Data Save Error	<ol style="list-style-type: none"> 1. Power off for 2 minutes, then restart. 2. If startup fails, replace the controller. 3. Contact product support.

Error Code	Error Description	Corrective Action
E22	Communication Error (Console ↔ Lower Control Board)	<ol style="list-style-type: none"> 1. Check if the cable between console and controller is loose or disconnected. 2. Check if the controller is damaged. 3. Check if the console is damaged. 4. Power off for 2 minutes, then restart. 5. Contact product support.
CONNECTION ERROR	Communication Error (Console ↔ Screen)	<ol style="list-style-type: none"> 1. Check if the cable between console and screen is loose or disconnected. 2. Check if cable connection between screen and controller is stable. 3. Check if the console is damaged. 4. Power off for 2 minutes, then restart. 5. Contact product support.
E30	Motor Calibration / Zero Position Error	<ol style="list-style-type: none"> 1. Replace the controller. 2. Contact product support.
E31	Overtemperature	<ol style="list-style-type: none"> 1. Wait for the motor temperature to return to normal, then restart. 2. Contact product support.
E32	Motor Reversed	<ol style="list-style-type: none"> 1. Check if the motor UVW wires are connected properly. 2. Contact product support.
E33	Motor Parameter Error	<ol style="list-style-type: none"> 1. Contact manufacturer for correct motor parameters. 2. Contact product support.
E50	Other Errors	<ol style="list-style-type: none"> 1. Power cycle the machine. 2. Contact product support.

MANAGER→Update

The USB button will only highlight when a file is detected by USB.

The OTA button will only highlight when OTA detects that there is a file on the server.

NOTE: The images shown may differ from your console.

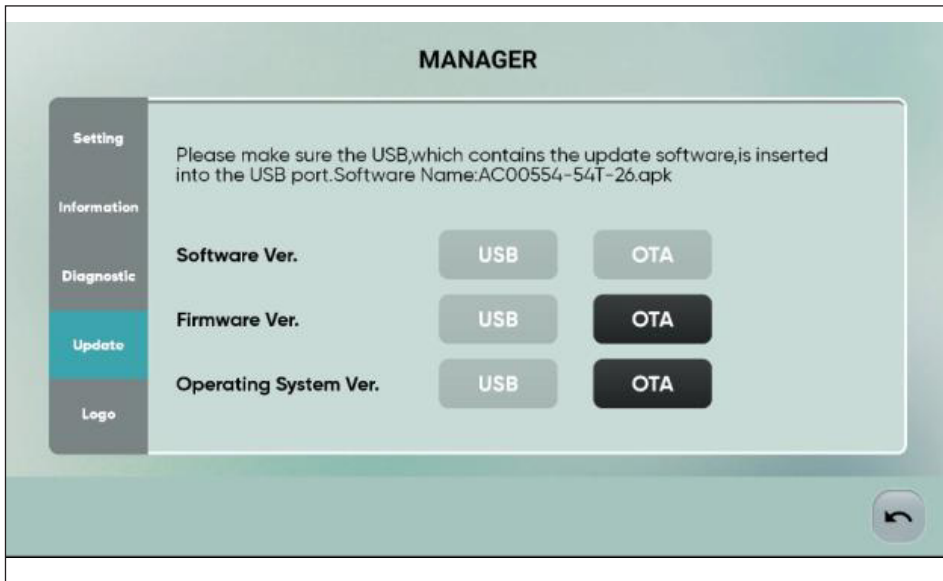

To update by USB:

1. Press **USB**.
2. The console displays a pop up window as it searches for the file...
3. To update, press **INSTALL**.
4. To update press **OPEN**.

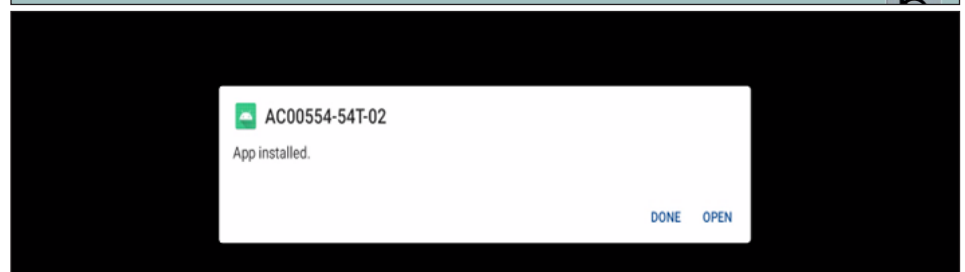
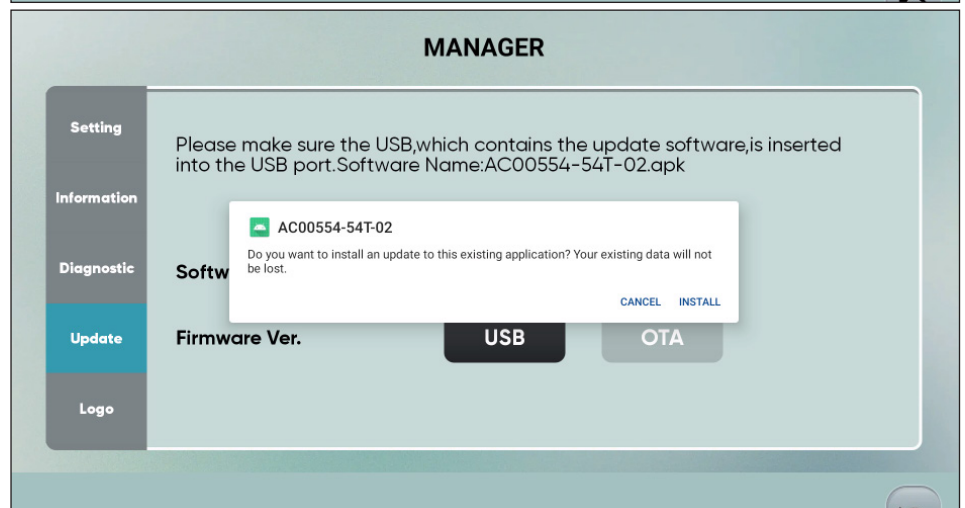
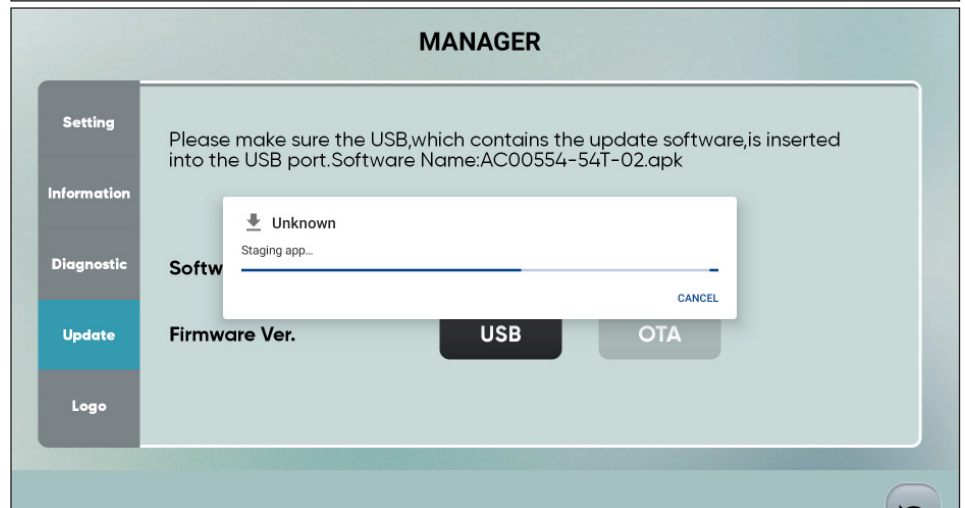
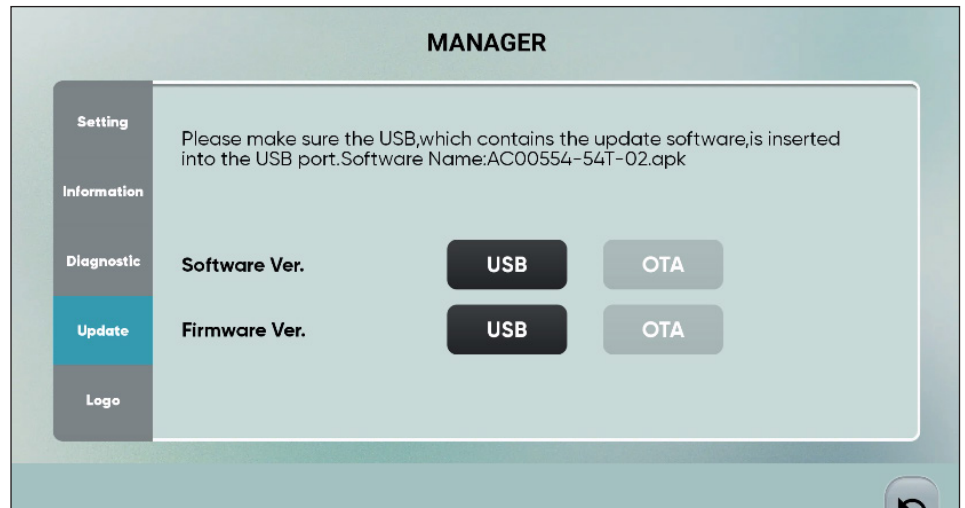

To update OTA :

1. Press **OTA**.
2. Press **Update**.
3. The console displays a series of update windows.
4. When the update is complete the console will automatically restart.

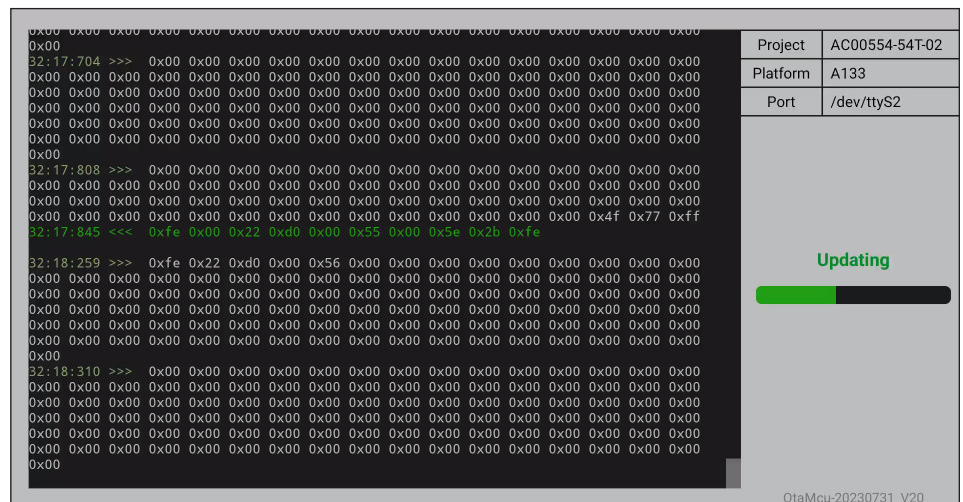
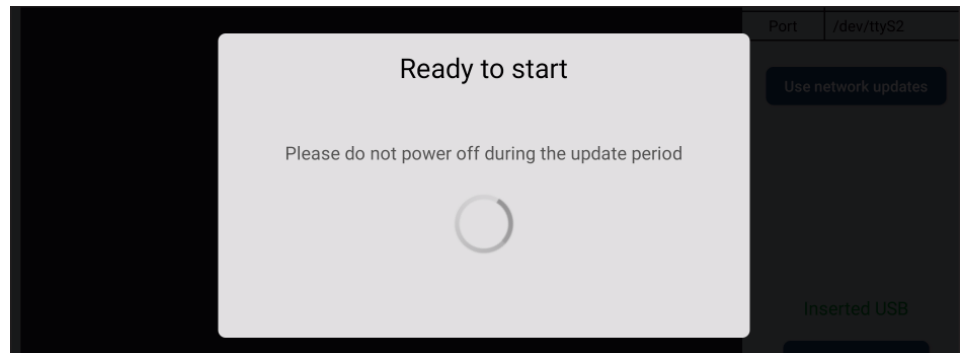
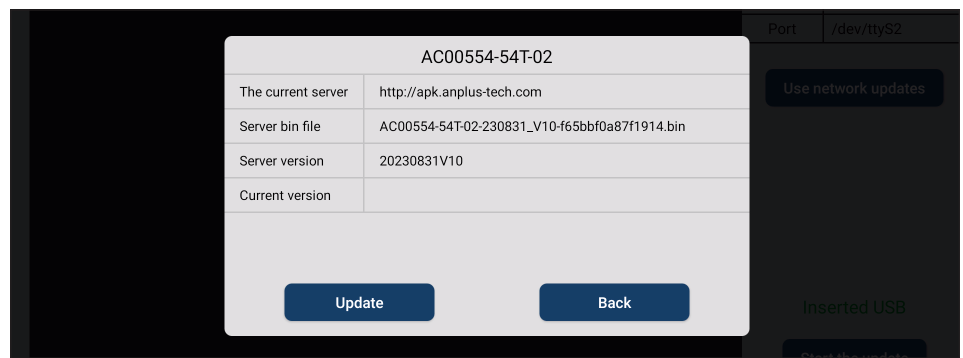
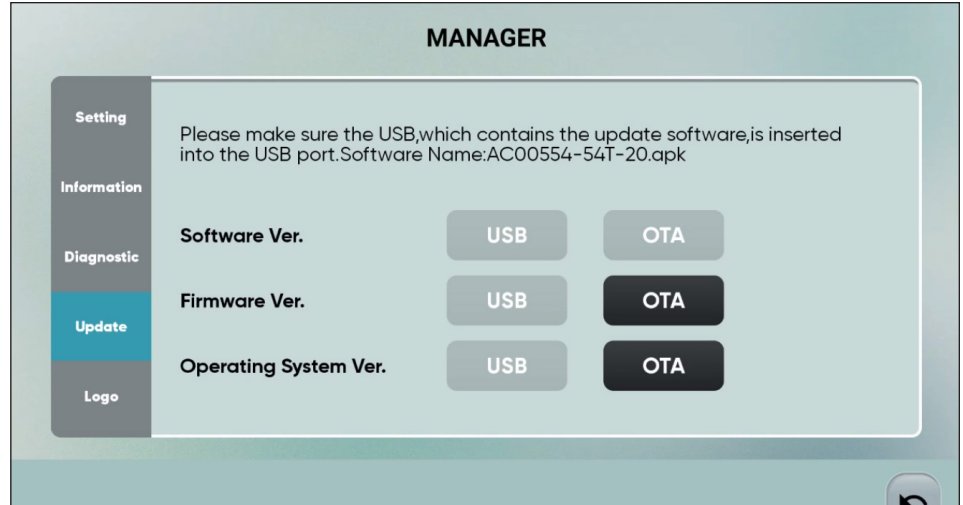

MANAGER → Logo

If you want to update the logo shown on the home screen, change the file name to LOGO.png and save it to a USB device.

Insert the USB device into the USB port and when an update-able file is detected, the **Update Logo** button light will light up.

The current Logo is shown on the left.

The new Logo from the USB is shown on the right.

When you press **Update Logo**, the new logo on the right overwrites the existing logo on the left.

NOTE: After updating the logo, the console needs to stay on for 2 minutes before powering off.

NOTE: The image shown may differ from your console.

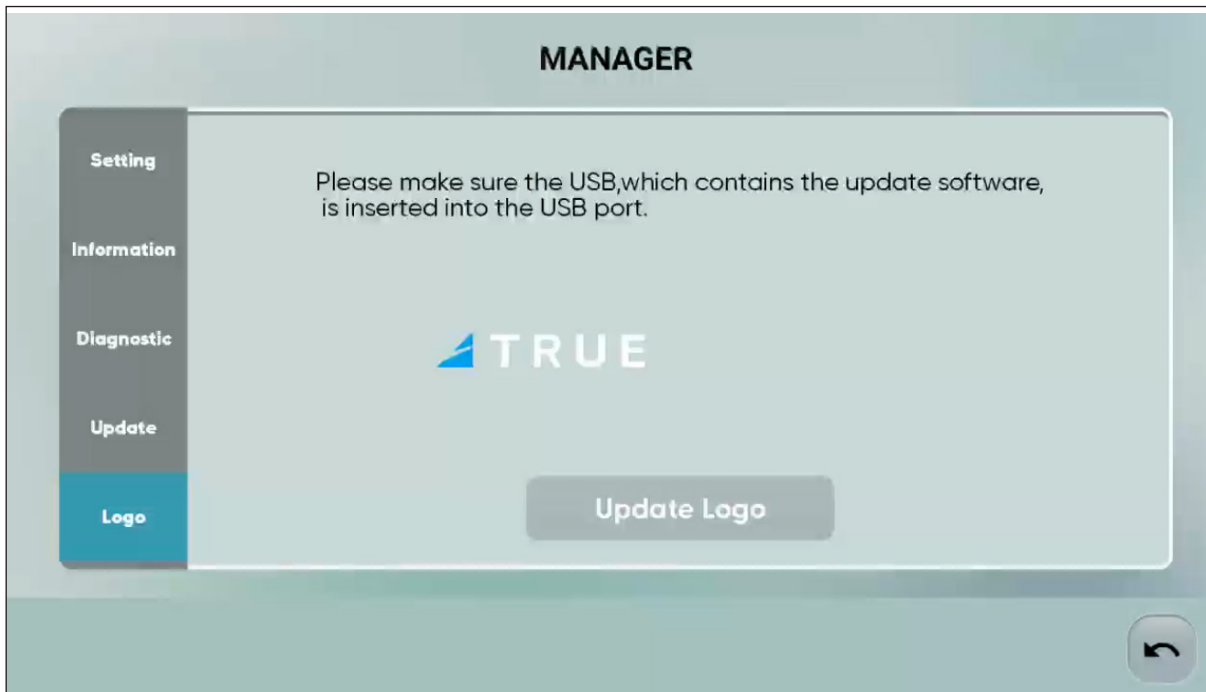

WARRANTY

IN HOME RESIDENTIAL LIMITED WARRANTY

Warranty does not cover damage or equipment failure resulting from or caused by improper assembly/installation, accident, misuse, abuse, unauthorized modification, or failure to provide reasonable and necessary maintenance.

See the base manual or visit the TRUE website for the warranty duration for this product.

Warranty does not cover damage or equipment failure resulting from or caused by improper assembly/installation, accident, misuse, abuse, unauthorized modification, or failure to provide reasonable and necessary maintenance.

Frame is the serialized base of the unit and does not include paint or coatings. Frame warranty will equal that of parts warranty unless, within 45 days of purchaser's receipt of this Product (A) the warranty is registered on-line or (B) if the form provided with equipment is filled in, signed by the original purchaser, and mailed to TRUE. If a valid receipt is not available, the Limited Frame Warranty period begins from the date of manufacture on the originally purchased equipment.

Drive Motor warranty will equal that of parts warranty unless, within 45 days of purchaser's receipt of this Product (A) the warranty is registered on-line or (B) if the form provided with equipment is filled in, signed by the original purchaser, and mailed to TRUE. If a valid receipt is not available, the Limited Drive Motor Warranty period begins from the date of manufacture on the originally purchased equipment.

Labor warranty is available for equipment located within United States. TRUE Fitness equipment is automatically covered under a 6-month Limited Labor Warranty. This 6-month Limited Labor Warranty begins from the date of purchase shown by a valid receipt. If a valid receipt is not available, the 6-month Limited Labor Warranty period begins from the date of manufacture on the originally purchased equipment.

Wear Items include: batteries, covers, caps, badges, paint, pedal straps, toe clips, elliptical pedal inserts, foot pads, Coax/TV, HDMI, USB, mirroring or Ethernet connections, and safety key.

All TRUE Fitness products are distributed by TRUE and are warranted to the original product purchaser and the parts of the TRUE product (the "Product") listed below. During the applicable Warranty Period, the Product, under normal use and service, shall be free of manufacturing defects in workmanship and materials.

NOTE:

- Standard shipping is included with warranty part replacement.
- Shipping for warranty frame or replacement is included for the period of three years from the original date of purchase.

All Warranty Items are "LIMITED"

- This limited warranty does not cover damage or equipment failure resulting from or caused by improper assembly/installation, failure to follow instructions and warnings in owner's manual, accident, misuse, abuse, unauthorized modification, failure to provide reasonable and necessary maintenance, software version upgrades, compatibility with third party/aftermarket hardware, software, applications, or websites.
- TRUE's liability shall under no circumstances exceed the actual amount paid by you for the product, nor shall TRUE under any circumstances be liable for any consequential, incidental, special or punitive damages or losses, whether direct or indirect.
- Some states or countries do not allow the exclusion or limitation of incidental or consequential damages, so the above limitation or exclusion may not apply to you.

- TRUE will neither assume nor authorize any person to assure for us any other obligation or liability concerning the sale of this Product. Under no circumstances shall TRUE be liable under this warranty, or otherwise, of any damage to any person or property, including any lost profits or lost savings, for any special, indirect, secondary, incidental, or consequential damages arising out of the use of or inability to use this Product.
- This limited warranty, which is given expressly and in lieu of all other express warranties, constitutes the only warranty made by TRUE.
- The remedies described herein are your sole and exclusive remedies and TRUE's entire liability for any breach of this limited warranty.
- No one is authorized to change, modify, or extend the terms of this limited warranty.
- This limited warranty is in lieu of all other warranties of any kind either expressed or including but not limited to implied warranties of merchant.
- This limited warranty applies to the product only while the product remains in the possession of the original purchaser and is not transferable.
- This limited warranty becomes VALID ONLY if the Product is initially assembled/installed by a TRUE authorized dealer/technician (if anyone other than a TRUE authorized dealer/technician initially assembles and installs the Product, this limited warranty will be void unless the written authorization of TRUE is first obtained).
- The "Warranty Period" for this limited warranty shall be for the duration forth in the applicable charts, beginning from the date of original purchase; provided, however, except to the extent prohibited by applicable law, the "Warranty Period" shall only be 6-months for Labor, 5-years for Frame, 5-years for Drive Motor (from the date of original purchase) unless, within 45 days of purchaser's receipt of this Product (A) the warranty is registered on-line or (B) if the form provided with equipment is filled in, signed by the original purchaser, and mailed to TRUE.
- All serial numbers must be intact on the Product for this limited warranty to be valid.
- Installation or download of any 3rd party or after-market products will result in voided warranty. This includes, but is not limited to, electrical and mechanical parts, software, or applications.
- TRUE will ship to an authorized service provider any new or rebuilt replacement part or component, or at our option, replace or refund the Product.
- Replacement parts are warranted for the remaining portion of the original warranty period.
- Proof/receipts of necessary maintenance may be required within 30 days of requested warranty part or service.
- This limited warranty does not apply to the performance of the heart rate accuracy will not be warranted as performance varies, based on user's physiology, age, method of use, and other external factors.

WARRANTY REGISTRATION

Thank you for purchasing a TRUE product!

To ensure you get the most out of your purchase and receive the full benefits of our warranty, **you must register your product within 45 days of purchaser's receipt of this product.**

How to register your product:

- **Online:**
Simply visit our website at truefitness.com and register your product warranty in one simple step.
- **QR Code:**
Scan the QR code below with your smartphone to be taken directly to the registration page.



- **By Mail:**
Complete the information below and mail to:
TRUE Product Support
865 Hoff Road
St. Louis, MO 63366

PLEASE RETAIN THIS PORTION FOR YOUR RECORDS
BASE SERIAL NUMBER:
CONSOLE SERIAL NUMBER:



Warranty Registration

Base Serial Number

Console Serial Number (if applicable)

Purchase Date

Company (if applicable)

Customer Name (First and Last)

Email Address

Phone Number

Street Address

City

State

Postal Code

Country



CONTACT US
service@truefitness.com
1.800.883.8783

865 Hoff Road
St. Louis, MO 63366

[TRUEFITNESS.COM](https://www.truefitness.com)

