

**RESIDENTIAL
PERFORMANCE
RECUMBENT BIKE**

TRUE FITNESS



**SCAN FOR UP-TO-DATE
OWNER'S MANUAL**



**SCAN FOR
ASSEMBLY VIDEO**

**MODEL RR1-OB-35
MAN-RR1-OB-35 REV07**

**OWNER'S
MANUAL**



IMPORTANT—PLEASE READ

All products shown are prototype. Actual product delivered may vary. Product specifications, features, and software are subject to change without notice.

For the most up-to-date version of this manual, please see our website:

<https://shop.truefitness.com/services-support/user-manuals/>

CONTACTING OUR SUPPORT TEAM

To contact TRUE for any of your pre or post installation questions, please call our toll-free numbers Monday - Friday during normal business hours:

- Commercial Direct Customers and Corporate Accounts | 800.868.8783
- Retail Customers and Distributors | 800.883.8783

Or email us:

- Commercial Direct Customers and Corporate Accounts | service.direct@truefitness.com
- Retail Customers and Distributors | service@truefitness.com
- Service International | int.service@truefitness.com

When contacting TRUE, please have the following information ready:

- Serial Number of Unit
- Contact Information—Full Name, Email, and Phone Number
- Address of Facility or Residence
- Detailed Description Regarding Symptom of the Unit (along with pictures or video if applicable)

NOTE: Authorized service providers, dealers, and distributors may also use TRUE's online resource | portal.truefitness.com.

CONTACTING OUR SALES TEAM

Interested in owning more TRUE products? Please contact us with any product inquires so that we may direct you to the appropriate sales representative to help answer your questions.

- Phone | 800.426.6570
- Email | sales@truefitness.com

REPORTING FREIGHT CLAIMS OR PARTS DAMAGE

Unfortunately, sometimes materials can be damaged during shipment. If materials are damaged during shipment, please follow the guidelines below to determine the appropriate process for you to follow.

Severe Damage—Obvious damage to external packaging and internal product.

Please refuse the shipment and it will be returned to TRUE by the carrier. Contact TRUE product support by calling 800.883.8783 or sales support by calling 800.426.6570 Monday-Friday during normal business hours to notify us that the shipment has been refused. Once we have received the damaged shipment, a replacement shipment will be sent to you. If the shipment comes in multiple boxes, only refuse boxes with damage.

Slight Damage—Minimal damage to external packaging with unknown internal damage to product.

If the shipment has minimal damages and you are not sure if the actual product is damaged, you must sign the bill of lading as damaged when accepting the shipment. Once you have opened the box and you have determined something is indeed damaged, please gather the serial number, model number, description of damage, and photos of damage. Please make sure the photos include the damaged product as well as the damaged box the product arrived in. Contact TRUE product support (service@truefitness.com | 800.883.8783) or TRUE sales support (sales@truefitness.com | 800.426.6570) Monday-Friday during normal business hours.

Concealed Damage—No damage to external packaging but internal damage to product.

You may receive a shipment that looks intact and discover once the box has been opened that there are hidden damages. Please notify the carrier immediately. TRUE will not be able to file a claim if the carrier is not notified in a timely manner. Once you have called the carrier you will need to gather the serial number, model number, description of damage, and photos of damage. Contact TRUE product support (service@truefitness.com | 800.883.8783) or TRUE sales support (sales@truefitness.com | 800.426.6570) Monday-Friday during normal business hours.

TABLE OF CONTENTS

SAFETY INSTRUCTIONS

IMPORTANT SAFETY INSTRUCTIONS—SAVE THESE INSTRUCTIONS.....	5
POWER REQUIREMENTS.....	7
GROUNDING INSTRUCTIONS.....	7
SPACE REQUIREMENTS.....	8
SPECIFICATIONS.....	8
WARNING DECALS.....	9
COMPLIANCES.....	9
PROPER USE.....	10

ASSEMBLY INSTRUCTIONS

PREASSEMBLY CHECKLIST.....	11
ASSEMBLY STEPS.....	14

PRODUCT FEATURES

BASE OVERVIEW.....	28
CONSOLE OPTIONS.....	29

CARE AND MAINTENANCE

INSPECTION.....	30
CLEANING THE EQUIPMENT.....	30
LEVELING THE EQUIPMENT.....	30
PREVENTATIVE MAINTENANCE.....	31
LONG TERM STORAGE.....	31

ADDITIONAL INFORMATION

TROUBLESHOOTING.....	32
----------------------	----

WARRANTY INFORMATION

LIMITED WARRANTY.....	33
WARRANTY REGISTRATION.....	34

SAFETY INSTRUCTIONS

IMPORTANT SAFETY INSTRUCTIONS—SAVE THESE INSTRUCTIONS

This equipment intended for in-home use only. Do not use this product in any commercial, rental, school or institutional setting.

- Read and understand all instructions and warnings prior to use.
- Obtain a medical exam before beginning any exercise program. If at any time during exercise you feel faint, dizzy, or experience pain, stop and consult your physician.
- Obtain proper instruction prior to use.
- This unit is intended for in-home use only.
- For indoor use only.
- Inspect the unit for incorrect, worn, or loose components and do not use until corrected, replaced, or tightened prior to use.
- Do not wear loose or dangling clothing while using the unit.
- Care should be used when mounting or dismounting the unit.
- Read, understand, and test the emergency stop procedures before use.
- Disconnect all power before servicing the unit.
- Do not exceed maximum user weight of 350 lbs / 159 kg.
- Keep the top side of the moving surface clean and dry.
- Keep children and animals away.
- Use caution when moving and assembling unit.
- All exercise equipment is potentially hazardous. If attention is not paid to the conditions of equipment usage, death, or serious injury could occur.

⚠ DANGER: To reduce the risk of electric shock, always unplug this product when not in use, before cleaning, or attempting any maintenance activity. Do not handle the plug with wet hands.

⚠ WARNING: Heart rate monitoring systems may be inaccurate. Over exercising may result in serious injury or death. If you feel faint stop exercising immediately.

⚠ WARNING: To reduce the risk of burns, fire, and electric shock or injury to persons, follow these instructions:

- Health related injuries may result from incorrect or excessive use of exercise equipment.
- TRUE STRONGLY recommends seeing a physician for a complete medical exam before undertaking an exercise program, particularly if the user has a family history of high blood pressure or heart disease, is over the age of 45, smokes, has high cholesterol, is obese or has not exercised regularly in the past year. Additionally, TRUE recommends consulting a fitness professional on the correct use of this product.
- Equipment should be immediately taken out of use if it fails to work properly or when a warning is presented electronically.
- When using this exercise machine, basic precautions should always be followed.
- Use this equipment only for its intended use as described in this manual.

- Do not move the equipment by lifting the console. Do not use the console as a handlebar during a workout.
- This product can expose you to chemicals including Toluene and Acrylamide which are known to the State of California to cause Cancer and birth defects or other reproductive harm. For more information, go to www.P65Warnings.ca.gov.
- Keep equipment stable on flat ground.
- This product is for indoor use only.
- Risk of personal injury-crushing hazard when equipment is in operation. Keep feet, hands, and fingers away from moving parts.
- Replace warning labels that may be worn, damaged, or missing.
- Replace any non-working or damaged components, remove the unit from service until repair is performed.
- Do not operate the equipment while being covered with a blanket, pillow, plastic, or anything that insulates or stops airflow. Keep air openings free of lint, hair or any obstructing material.
- To avoid serious injury, remove and store the power cord when the machine is not in use.
- This appliance should never be left unattended when plugged in.
- Do not use any type of extension cord with this product.
- Never operate a TRUE product if it has a damaged power cord or electrical plug, or if it has been dropped, damaged, or even partially immersed in water.

- Use a TRUE AC power cord or AC/DC adapter only.
- Position this product so the power cord plug is accessible to the user.
- Keep the power cord away from heated surfaces. Do not pull the equipment by the power cord or use the cord as a handle. Do not run the power cord along the side or under the equipment.
- If the electrical supply cord is damaged it must be replaced by the manufacturer, an authorized service agent, or a similarly qualified person to avoid a hazard.
- This product must be connected to a properly grounded electrical outlet.
- To disconnect, turn power OFF at the ON/OFF switch if applicable, then remove plug from electrical outlet. On the machine power switch, (I) means that the machine power is **ON** and (O) means the machine power is **OFF**.
- Never insert objects into any openings in this product. If an object should drop inside, turn off the power, unplug the power cord from the outlet and carefully retrieve it. If the item cannot be reached, contact TRUE product support.
- Any changes or modifications to this equipment could void the product warranty.
- Do not use this product in areas where aerosol spray products are being used or where oxygen is being administered. Such substances create the danger of combustion and explosion.
- Do not use this product outdoors, near water, while wet, or in areas of high humidity including extreme temperature changes.
- Close supervision is necessary when used near children under the age of 15, or disabled persons.
- This equipment is not intended for use by persons with reduced physical, sensory, or mental capabilities, or lack of experience and knowledge, unless they are supervised or have been given instruction concerning use of the equipment by a person responsible for their safety.
- Children shall not play with the appliance.
- Cleaning and user maintenance shall not be made by children without supervision.
- Wear shoes with rubber or high traction soles. Do not use shoes with heels, leather soles, cleats or spikes. Make sure no stones are embedded in the soles. Do not use this product in bare feet. Keep all loose clothing, shoelaces and towels away from moving parts.
- To avoid injury, attach the safety clip to clothing before use.
- Avoid the possibility of bystanders being struck or caught between moving parts by making sure that they are out of reach of the equipment while it is in motion.
- Do not use typing or web surfing features at excessive speeds. Always stabilize yourself when using typing or web surfing features. (Varies by console option.)
- Never place liquids of any type directly on the unit except in the accessory tray or bottle holders. Containers with lids are recommended.
- Always follow the console instructions for proper operation.
- Do not use the contact heart rate grips as a handlebar during a workout.
- Avoid exiting equipment while leaving the tread belt in motion.
- Never walk or jog backwards on the equipment.
- Allow only one person at a time on the equipment while it's operating.
- Do not allow animals on or near the equipment while in operation.
- Do not reach into or underneath the unit, or tip it on its side during operation.
- Do not use if you have a cold or fever.
- Do not change the incline of the equipment by placing objects under it.
- Do not use attachments not recommended by the manufacturer.
- Allow only trained personnel to service this equipment.
- It is the sole responsibility of the owner/operator to ensure regular and scheduled maintenance is performed.

POWER REQUIREMENTS

Read and understand all instructions before plugging any TRUE power cord into an electrical outlet.

GROUNDING INSTRUCTIONS

This product must be grounded. If the product malfunctions or breakdowns, grounding provides a path of least resistance for electric current to reduce the risk of electric shock. This product is equipped with a cord having an equipment grounding conductor and a grounding plug. The plug must be plugged into an appropriate outlet that is properly installed and grounded in accordance with all local codes and ordinances.

⚠ DANGER:

- Improper connection of the equipment grounding conductor can result in risk of electrical shock.
- Check with a qualified electrician or service provider if you are in doubt as to whether the equipment is properly grounded or installed on a dedicated line.
- Seek a qualified electrician to perform any modifications to the cord or plug. TRUE is not responsible for injuries or damages as a result of cord or plug modification.
- To reduce the risk of burns, fire, electric shock, or injury, it is imperative to connect each product to a properly grounded 110V or 220V electrical outlet. The voltage required for your unit is located on the serial number decal (usually on the front of the unit). Depending on where you live voltage requirements differ.

- Some TRUE products require a circuit rated 110V, 60 Hz, and 20 amps. In the United States, most residential homes have circuits rated 110V, 60 Hz, and 15 amps. If your unit requires a 20 amp outlet, contact an electrician to install a dedicated 20 amp circuit prior to use.
- **110 Volt**—This model is for use on a nominal 110V circuit and has a grounding plug that looks like the plug illustrated below. Make sure the product is connected to an outlet having the same configuration as the plug. No adapter should be used with this product.

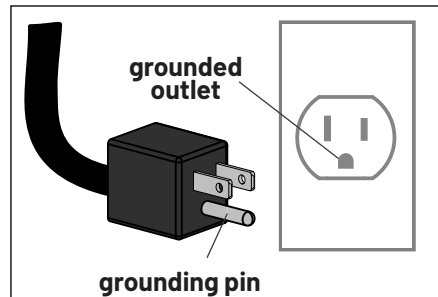

Power Information						
Model	Line Voltage (V)	Frequency (Hz)	Rated Current (Amps)	Number of Units per Circuit	Plug/Outlet	Max Power Dissipation (Watt)
RR1-0B-35	110	50/60Hz	15	1	NEMA 5-15 	1230

SPACE REQUIREMENTS

TRUE recommends leaving a minimum of 24" (61cm) on each side of the equipment and a 79" (200cm) safety zone at the rear of the equipment.

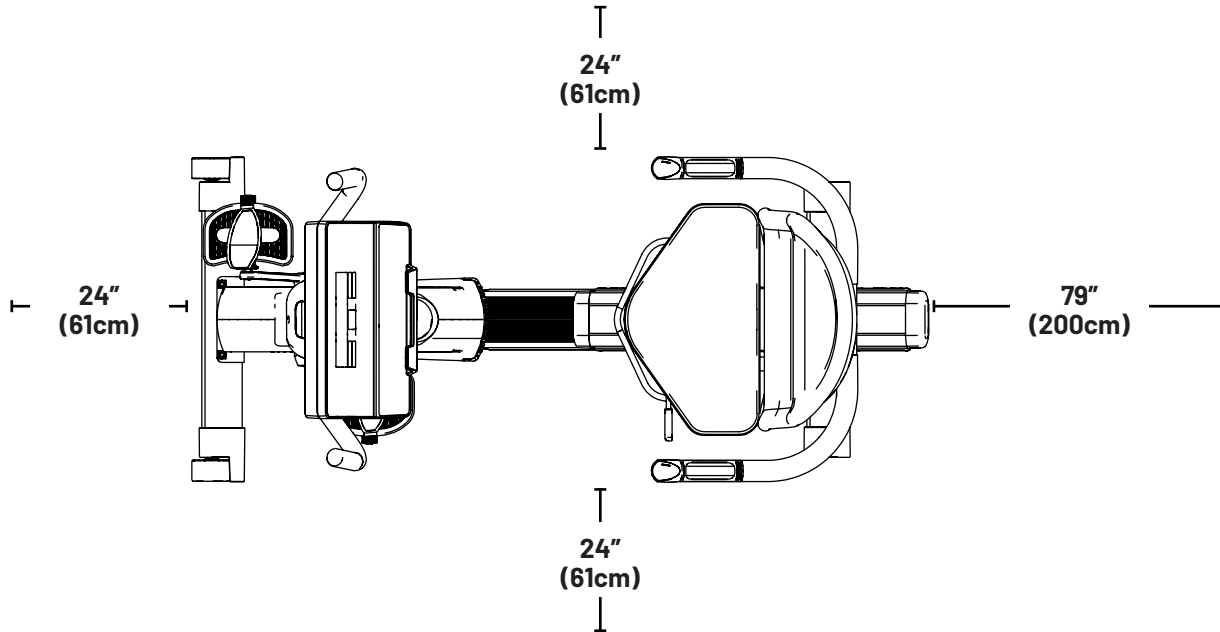

SPECIFICATIONS

- **DIMENSIONS (L X W X H)**
58" x 27" x 50.5" / 147.32 cm x 68 cm x 128.27 cm
- **MACHINE WEIGHT**
163 lbs / 74 kg
- **MAXIMUM USER WEIGHT**
350 lbs / 159 kg

WARNING DECALS

⚠ WARNING: Replace warning labels that may be worn, damaged, or missing.

To replace any worn or missing decals contact TRUE product support (service@truefitness.com | 800.883.8783).



S/N: 24-000000X
MDL: C4RLBKB

TRUE FITNESS		Model No.
TRUE FITNESS TECHNOLOGY, INC. 865 HOFF RD. ST. LOUIS, MO 63366, USA		RR1-0B-35
	CONFORMS TO ANSUL STD. 1647	Serial No./Date Code
	Intertek 3195202	24-RR10B0001A
CERTIFIED TO CAN/CSA STD. C22.2 NO.63		Rating: 9V DC, 40mA
Intertek Testing Services, Taiwan Ltd.		MADE IN TAIWAN

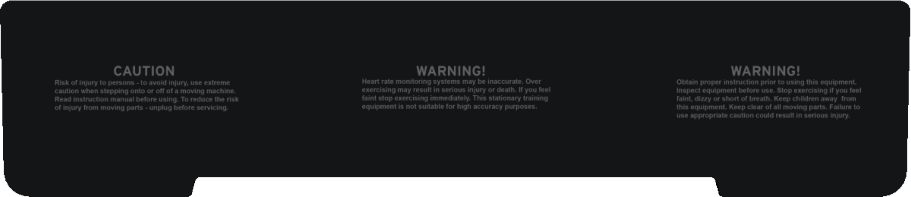

COMPLIANCES

This equipment complies with all applicable codes and regulations. For a complete list of compliances, please visit www.truefitness.com.

PROPER USE

Proper Training Position

- Once seated, users should place their feet on the pedals (A).
- When pedaling, the user should be able to extend their legs fully while pedaling; if users do not have enough room to fully extend their legs, they should adjust their seat position (B) until their legs are able to comfortably extend. Additionally, if users legs feel overly stretched when they're extended, the seat needs a lower adjustment.
- During a workout the users hand should grasp the handlebars (C).
- To safely exit, confirm the workout has ended and the console has returned to the Home screen in addition to the pedals coming to a complete stop. While firmly grasping the handlebars to maintain balance, slowly slide your body off the seat and feet from the pedals to transition to a standing position free from the bike.



ASSEMBLY INSTRUCTIONS

NOTE: Supplemental video available [@TRUEFitnessservicevids](https://www.youtube.com/@TRUEFitnessservicevids).

PREASSEMBLY CHECKLIST

BASIC GUIDELINES FOR SETTING UP THE EQUIPMENT

After removing the equipment from the packaging, place the equipment on a clean, level surface. Make sure the electrical cord easily reaches a grounded three-pronged outlet.

⚠ DANGER: Do not use an extension cord or ungrounded outlet. The ground helps prevent electrical damage to your equipment and enhances your safety by helping to prevent shock. Check with a qualified electrician or serviceman if you are in doubt as to whether the equipment is properly grounded. Do not modify the plug provided with the unit if it will not fit the outlet. Have a proper outlet installed by a qualified electrician.

⚠ CAUTION:



Use caution when assembling the equipment. Unpacking and assembling of this product is a two person task.



Use caution when unpacking this product. Avoid damage to the product. **DO NOT** use a box cutter. **DO NOT** slice into the packaging.

VERIFY BOX CONTENTS

IMPORTANT! Please verify box contents. If you have questions, or if there are any missing parts, contact product support (service@truefitness.com | 800.883.8783).

TOOLS NEEDED FOR ASSEMBLY		INCLUDED IN BOX
5mm Allen Wrench		YES
6mm Allen Wrench		YES
8mm Allen Wrench		YES
15mm Wrench		YES

TOOLS NEEDED FOR ASSEMBLY		INCLUDED IN BOX
#2 Phillips Screwdriver		NO
Wire Cutters		NO
Torque Wrench With 15mm Head		NO
19mm Wrench		NO

BOX CONTENTS

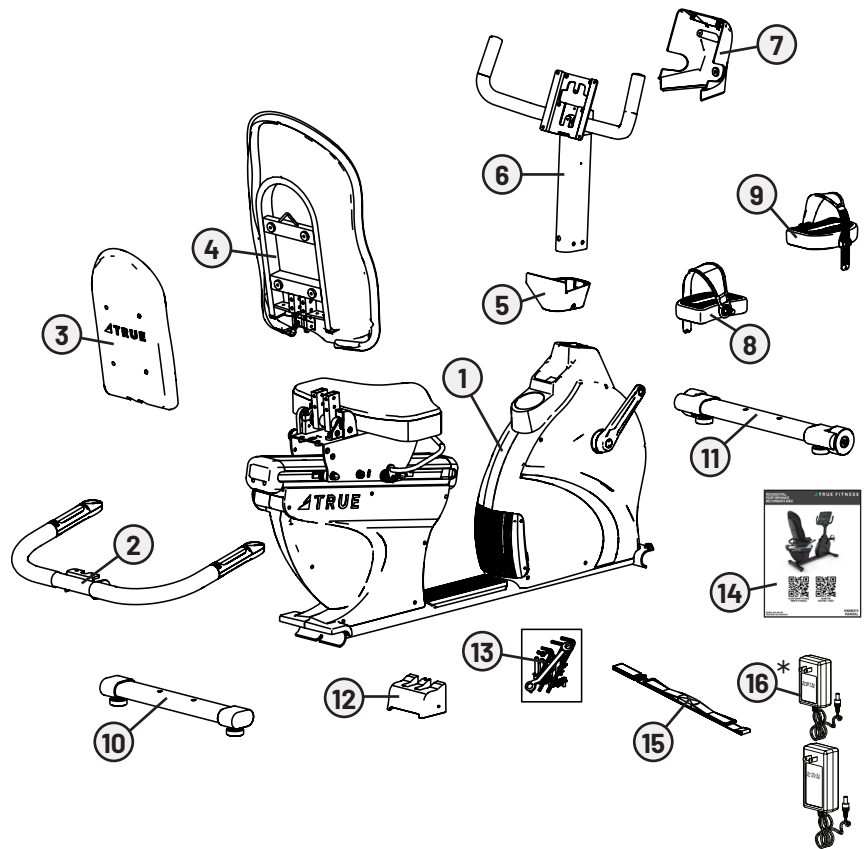

ITEM	DESCRIPTION	QTY
1	Base	1
2	Seat Handlebar	1
3	Seat Back Cover	1
4	Seat Back	1
5	Bottom Console Cover	1
6	Front Mast	1
7	Rear Console Cover	1
8	Left Pedal	1
9	Right Pedal	1
10	Rear Stabilizer	1
11	Front Stabilizer	1
12	Rear Pivot Cover	1
13	Hardware Bag(s)	1
14	Manual	1
15	Chest Strap	1
16*	Power Adapter	1



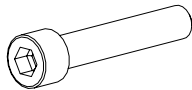

*The 9V, 1.3A power adapter is for LED consoles only. Touchscreen consoles require a 12V, 3A power adapter, which is included with touchscreen consoles.

HARDWARE BAG CONTENTS

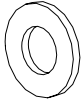
Step 1 and 2—Front and Rear Stabilizer Hardware

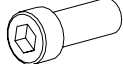

ITEM	DESCRIPTION	QTY
RCS0368	SHCS, M10-1.5 X 55MM 	4
FE0090	WASHER, SPRING, M10 	4
RCS0369	WASHER, FLAT, 10MM X 20MM, T=2MM 	4

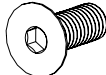
Step 4—Handlebar Hardware

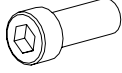

ITEM	DESCRIPTION	QTY
FE0179	SHCS, M8-1.25 X 20MM 	2
PS0099	WASHER, SPRING M8 	2
CM8-19FW	FLAT WASHER, 8MM X 19MM X 2MM 	2
CM8-125-20FH	BOLT FHCS M8x1.25_20 BZ 	4

HARDWARE BAG CONTENTS

Step 5—Seat Back Hardware

ITEM	DESCRIPTION	QTY
PS8054	SHCS, M6 X 16MM, LOCK PATCH 	8
FE0130	LOCK WASHER, M6-1.0 	8
FE0094	WASHER, FLAT 6.5 X 13 X 1.0T BLK 	8



Step 6—Rear Pivot Cover Hardware

ITEM	DESCRIPTION	QTY
FE0187	BHCS, M5-0.85 X 15MM 	2
RCS0382	WASHER, FLAT, 5.5MM X 15MM, T=1MM 	2

Step 7—Seat Back Cover Hardware

ITEM	DESCRIPTION	QTY
TC0056	BHCS, M5-0.8 X 20MM 	4

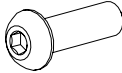

Step 10—Front Mast Hardware

ITEM	DESCRIPTION	QTY
RCS0404	BHCS, M10-1.5-20MM, ZP 	5
FE0090	WASHER, SPRING, M10 	5
RCS0369	WASHER, FLAT, 10MM X 20MM, T=2MM 	5

Step 12—Console Covers Hardware

ITEM	DESCRIPTION	QTY
TCS4029	PHMS, M4-0.7 X 10MM, PHILLIPS 	4

Tools

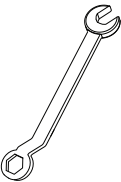
ITEM	DESCRIPTION	QTY
N/A	5MM ALLEN WRENCH 	1
N/A	6MM ALLEN WRENCH 	1
N/A	8MM ALLEN WRENCH 	1
N/A	15MM WRENCH 	1

ASSEMBLY STEPS

Step 1—Attach Rear Stabilizer

Tools Used in this Step	
8mm Allen Wrench	

Parts Used in this Step			
Item	Part	Description	Qty
1	RB0002-35	REAR STABILIZER ASSEMBLY	1
2	RCS0368	SHCS, M10-1.5 X 55MM	2
3	FE0090	WASHER, SPRING, M10	2
4	RCS0369	WASHER, FLAT, 10MM X 20MM, T=2MM	2

- A. Rotate the bike frame forward on the metal front stabilizer bracket.
- NOTE:** At least one person should hold the bike frame, while another installs the rear stabilizer.
- B. Using a 8mm allen wrench, install the rear stabilizer into the metal bracket using two M10 socket head cap hex screws, spring washers, and flat washers.

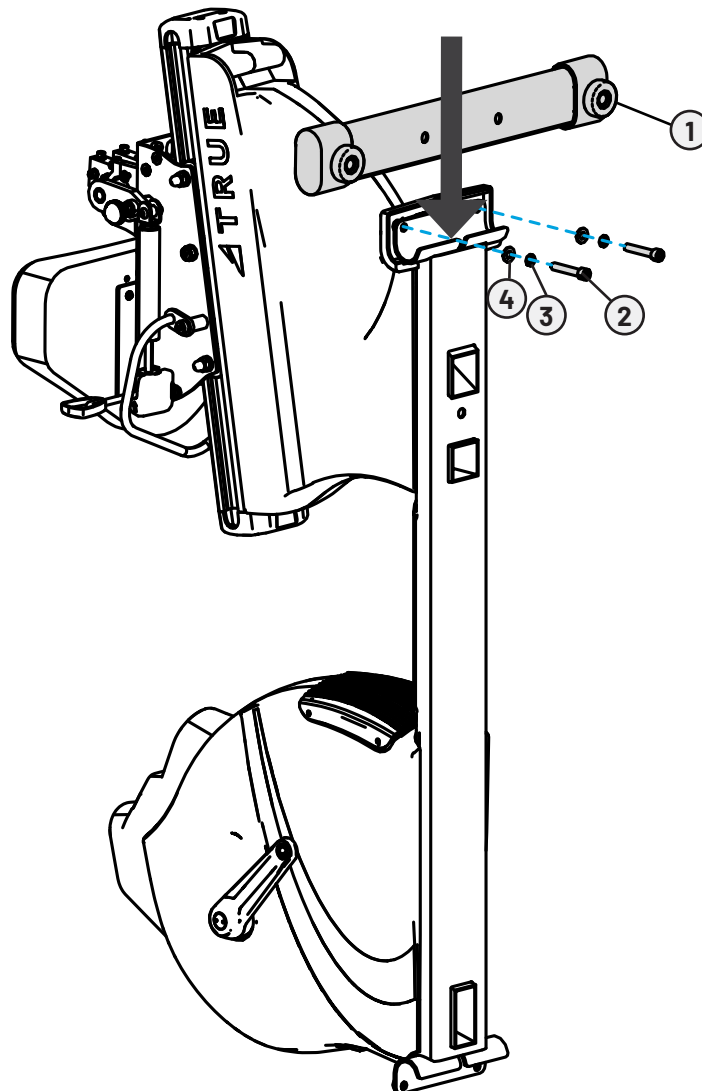

Step 2—Attach Front Stabilizer

Tools Used in this Step	
8mm Allen Wrench	

Parts Used in this Step			
Item	Part	Description	Qty
1	RB0001-35	FRONT STABILIZER ASSEMBLY	1
2	RCS0368	SHCS, M10-1.5 X 55MM	2
3	FE0090	WASHER, SPRING, M10	2
4	RCS0369	WASHER, FLAT, 10MM X 20MM, T=2MM	2

A. Rotate the bike frame backward on the rear stabilizer.

NOTE: At least one person should hold the bike frame, while another installs the front stabilizer.

B. Using a 8mm allen wrench, install the front stabilizer into the metal bracket using two M10 socket head cap hex screws, spring washers, and flat washers.

NOTE: If applicable, remove any packing debris from the seat rail assembly.

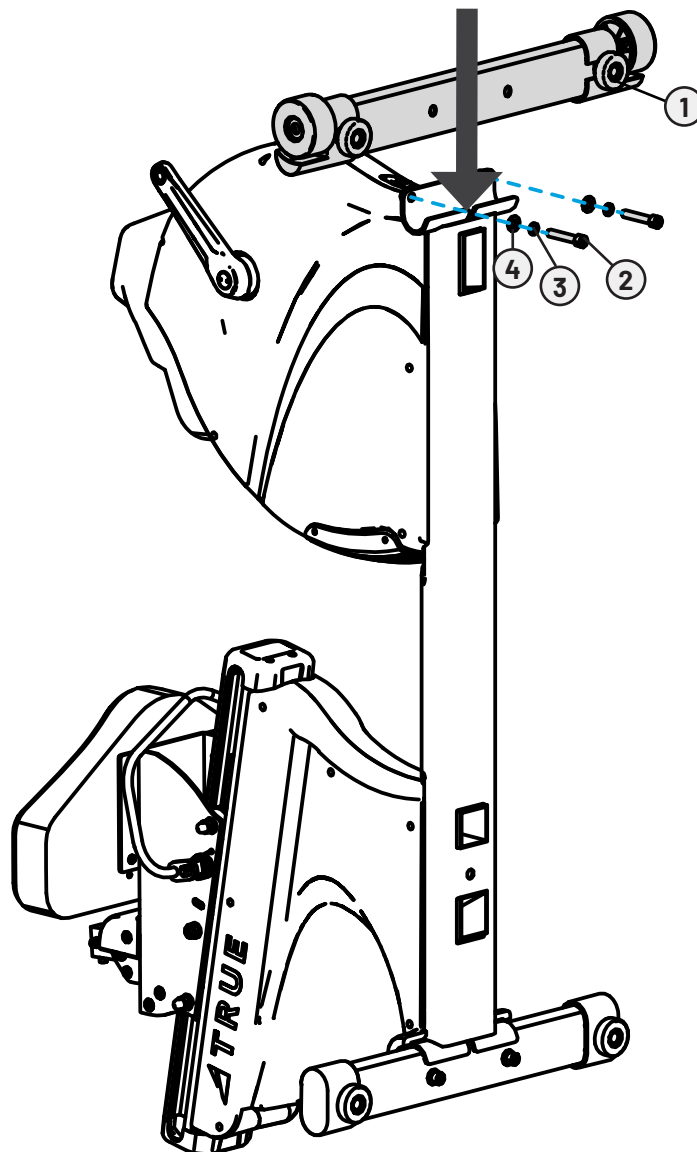



Step 3—Connect Seat Handlebar Cables

After making sure the handlebar is in the correct position, connect left and right contact heart rate cables.

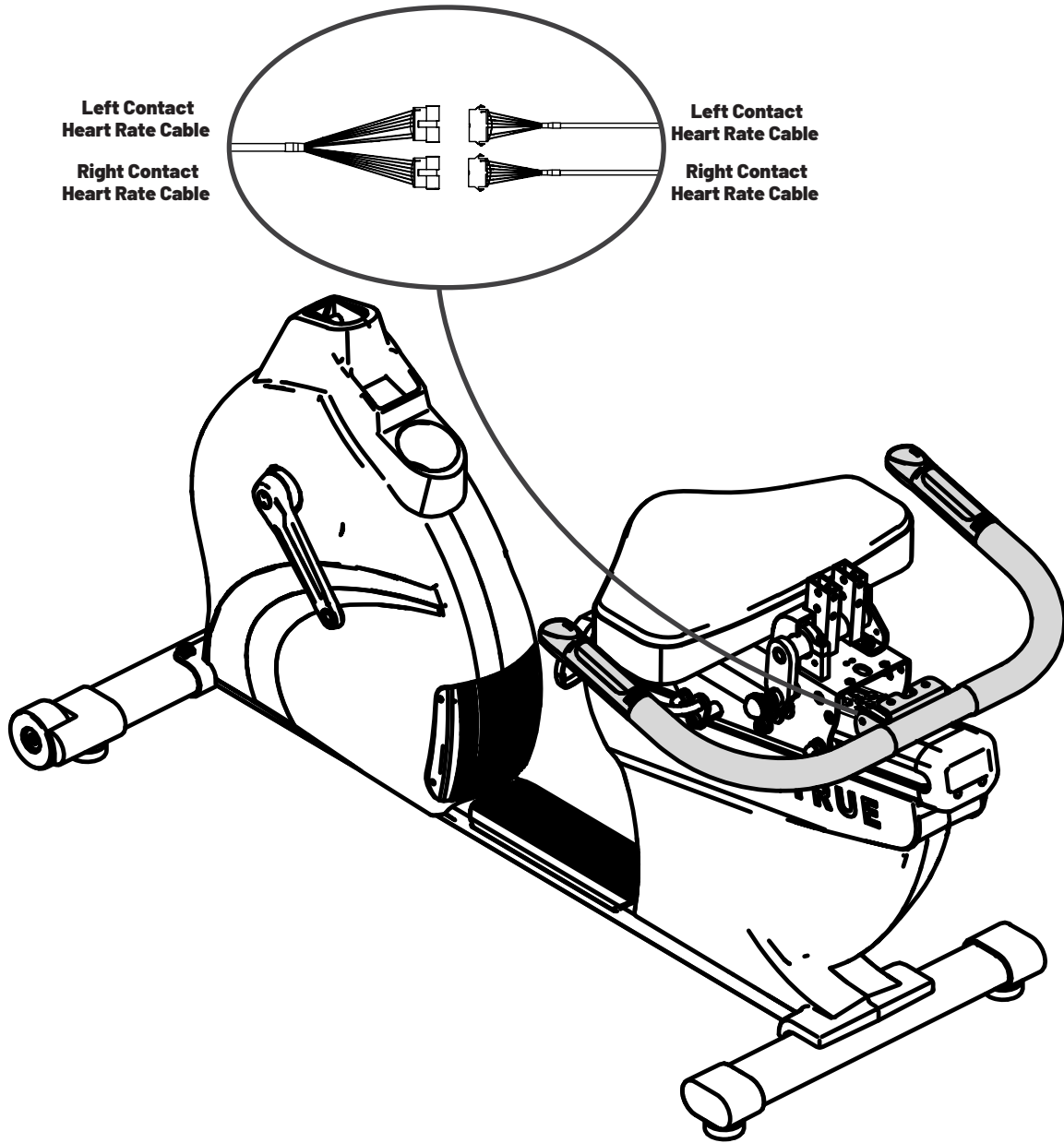
NOTE: At least one person should hold the handlebar in place while the other makes the cable connections.



Step 4—Attach Seat Handlebar

Tools Used in this Step	
5mm Allen Wrench	
6mm Allen Wrench	

Parts Used in this Step			
Item	Part	Description	Qty
1	RB0128-35	SEAT HANDLEBAR ASSEMBLY	1
2	CM8-125-20FH	BOLT FHCS M8x1.25_20 BZ	4
3	FE0179	SHCS, M8-1.25 X 20MM	2
4	PS0099	SPRING WASHER, M8	2
5	CM8-19FW	FLAT WASHER, 8MM X 19MM X 2MM	2

- Slide the seat handlebar bracket into the seat carriage.
- Using a 5mm allen wrench, tighten the four flat head cap screws on the sides of the seat carriage.
- Using a 6mm allen wrench, finish attaching the seat handlebar bracket to the seat carriage using two socket head cap screws, spring washers, and flat washers.

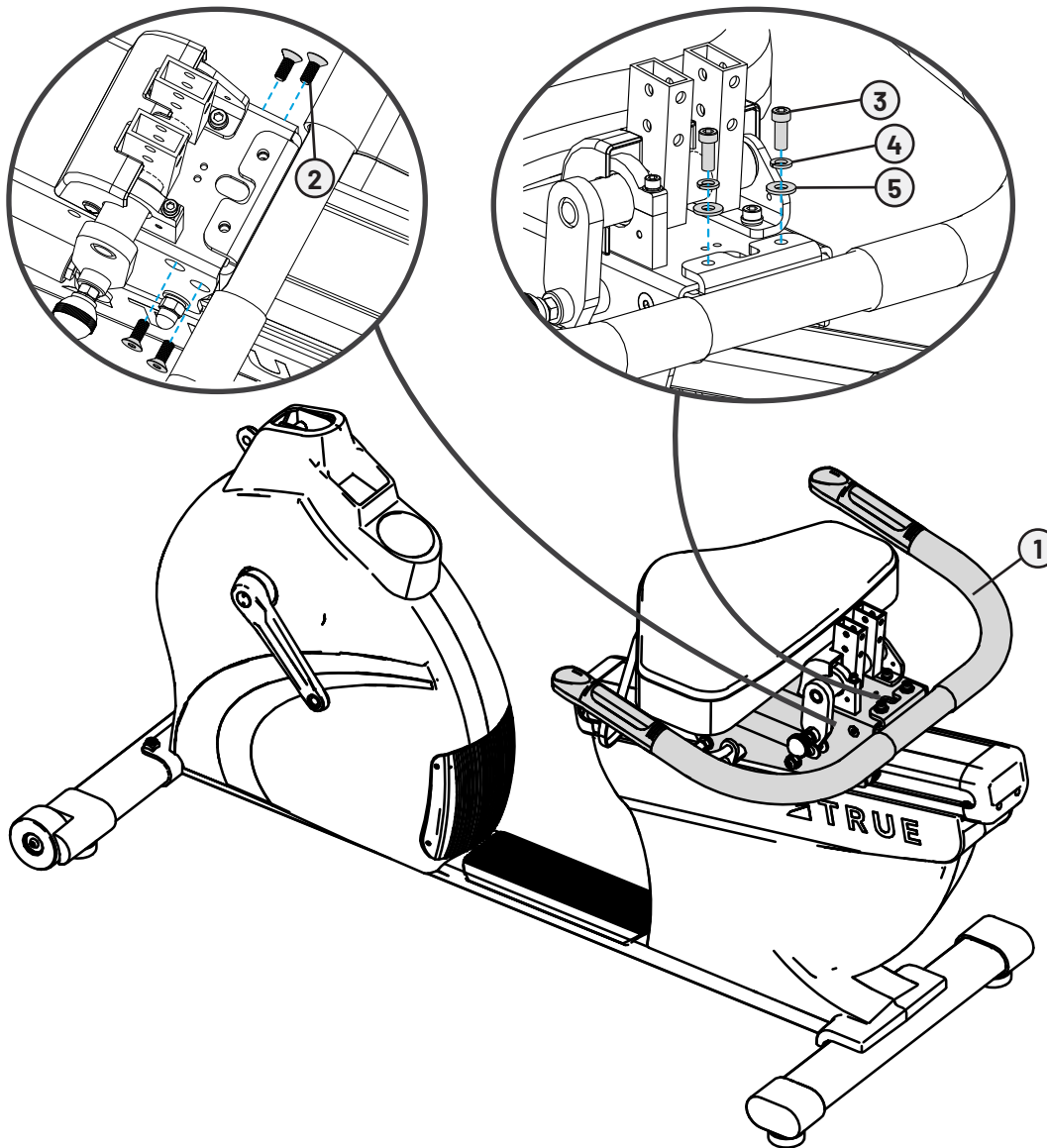

Step 5—Attach Seat Back

Tools Used in this Step	
5mm Allen Wrench	

Parts Used in this Step			
Item	Part	Description	Qty
1	RB0117	SEAT BACK ASSEMBLY	1
2	PS8054	SHCS, M6 X 16MM, LOCK PATCH	8
3	FE0130	LOCK WASHER, M6-1.0	8
4	FE0094	WASHER, FLAT 6.5 X 13 X 1.0T BLK	8

Using a 5mm allen wrench, install the seat back onto the seat carriage using eight socket head cap screws, spring washers, and flat washers.

NOTE: Tighten the four back screws before the four side screws.

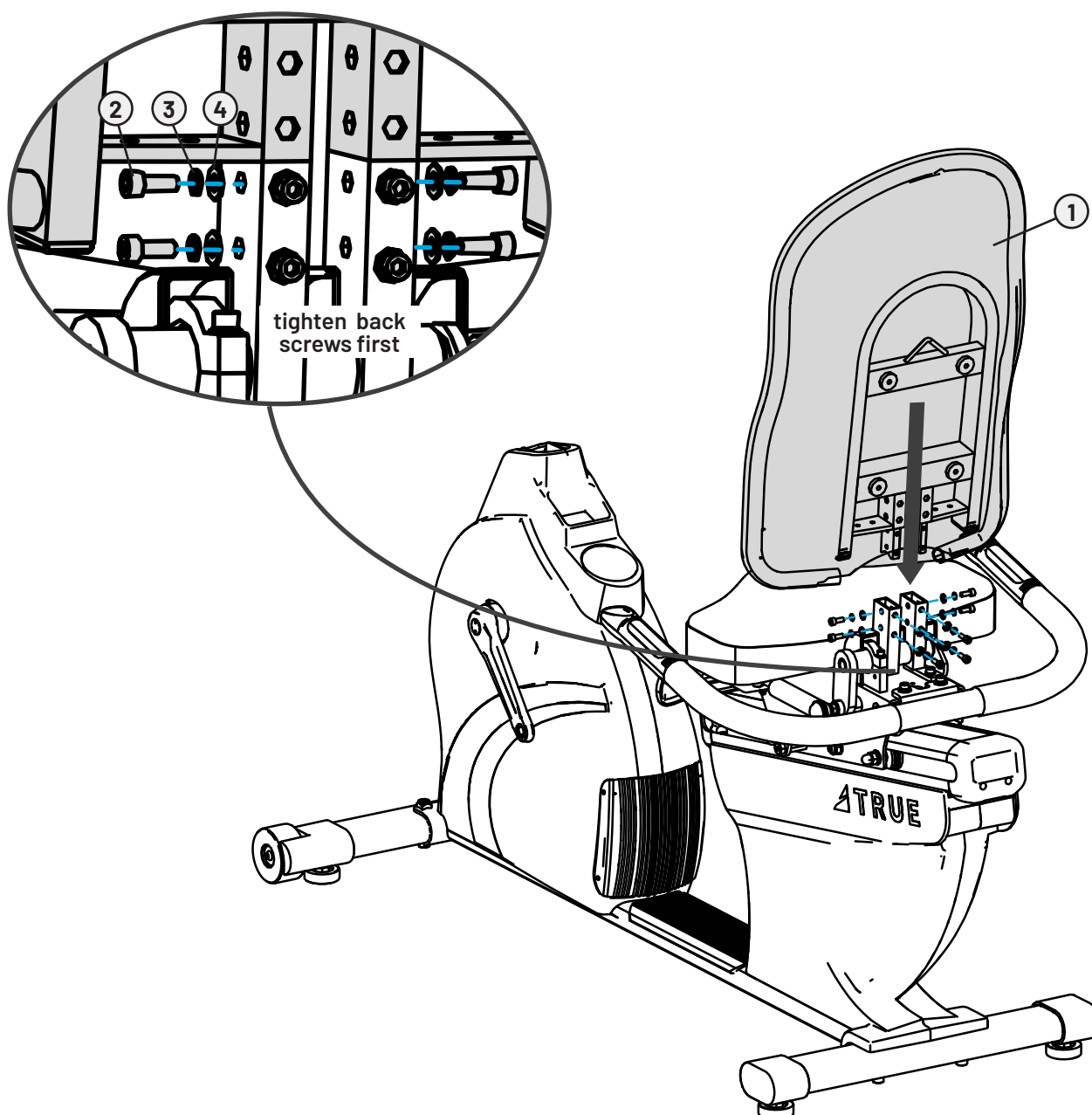

Step 6—Attach Rear Pivot Cover

Tools Used in this Step	
#2 Phillips Screwdriver	

Parts Used in this Step			
Item	Part	Description	Qty
1	RCS0036RBK	REAR PIVOT COVER	1
2	FE0187	BHCS, M5-0.85 X 15MM	2
3	RCS0382	WASHER, FLAT, 5.5MM X 15MM, T=1MM	2

A. Attach the rear pivot cover onto the seat carriage.

NOTE: The rear pivot cover should attach cleanly to the front pivot cover.

B. Using a #2 Phillips screwdriver, secure the rear pivot cover to the seat carriage using two screws and flat washers.

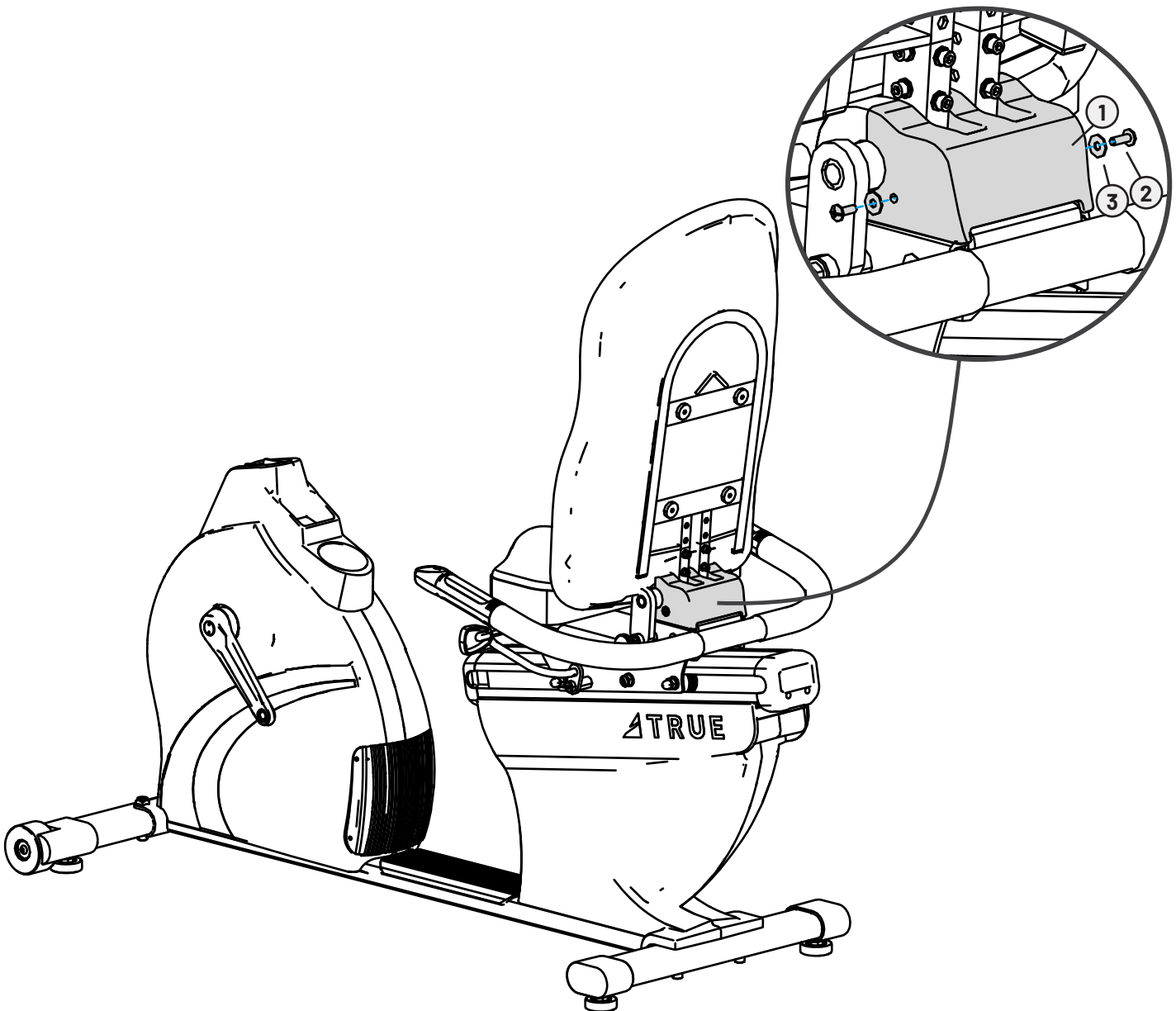

Step 7—Attach Seat Back Cover

Tools Used in this Step	
#2 Phillips Screwdriver	

Parts Used in this Step			
Item	Part	Description	Qty
1	RB0136BK	SEAT BACK COVER	1
2	TC0056	BHCS, M5-0.85 X 20MM	4

Using a #2 Phillips screwdriver, attach the seat back cover to the seat back using four screws.

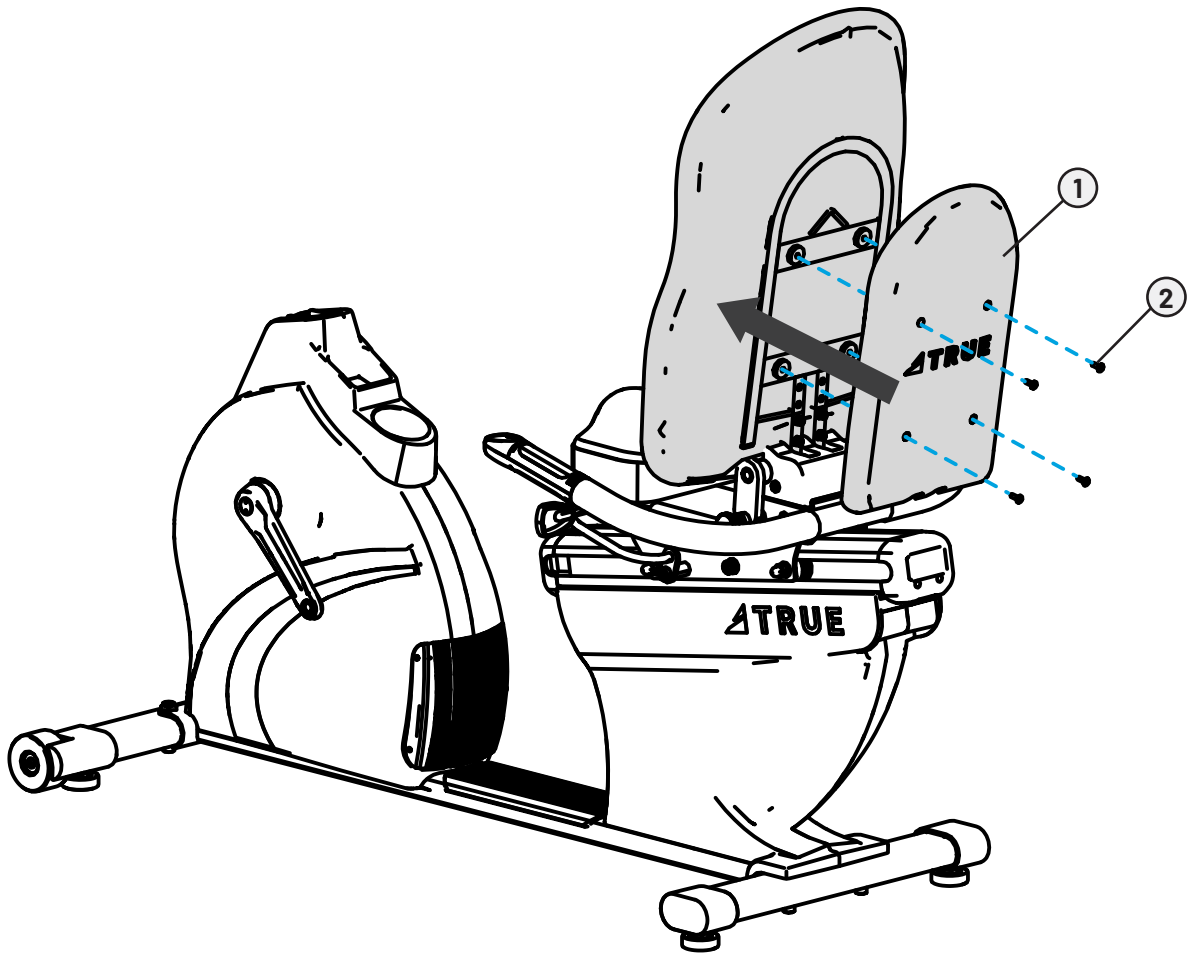

Step 8—Attach Pedals

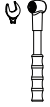
Tools Used in this Step	
15mm Wrench	
Torque Wrench With 15mm Head	

Parts Used in this Step			
Item	Part	Description	Qty
1	RB0076BKL	PEDAL ASSEMBLY LEFT	1
2	RB0076BKR	PEDAL ASSEMBLY RIGHT	1

- Using a 15mm wrench, attach each pedal to its corresponding crank.
- Securely tighten the pedal to the crank arm assemblies. It is strongly recommended to torque each pedal to 40 N-M (29.5 FT-LB) using an optional but preferred torque wrench with a 15mm head.

NOTE: The left pedal is reverse-threaded (turn counter-clockwise to tighten).

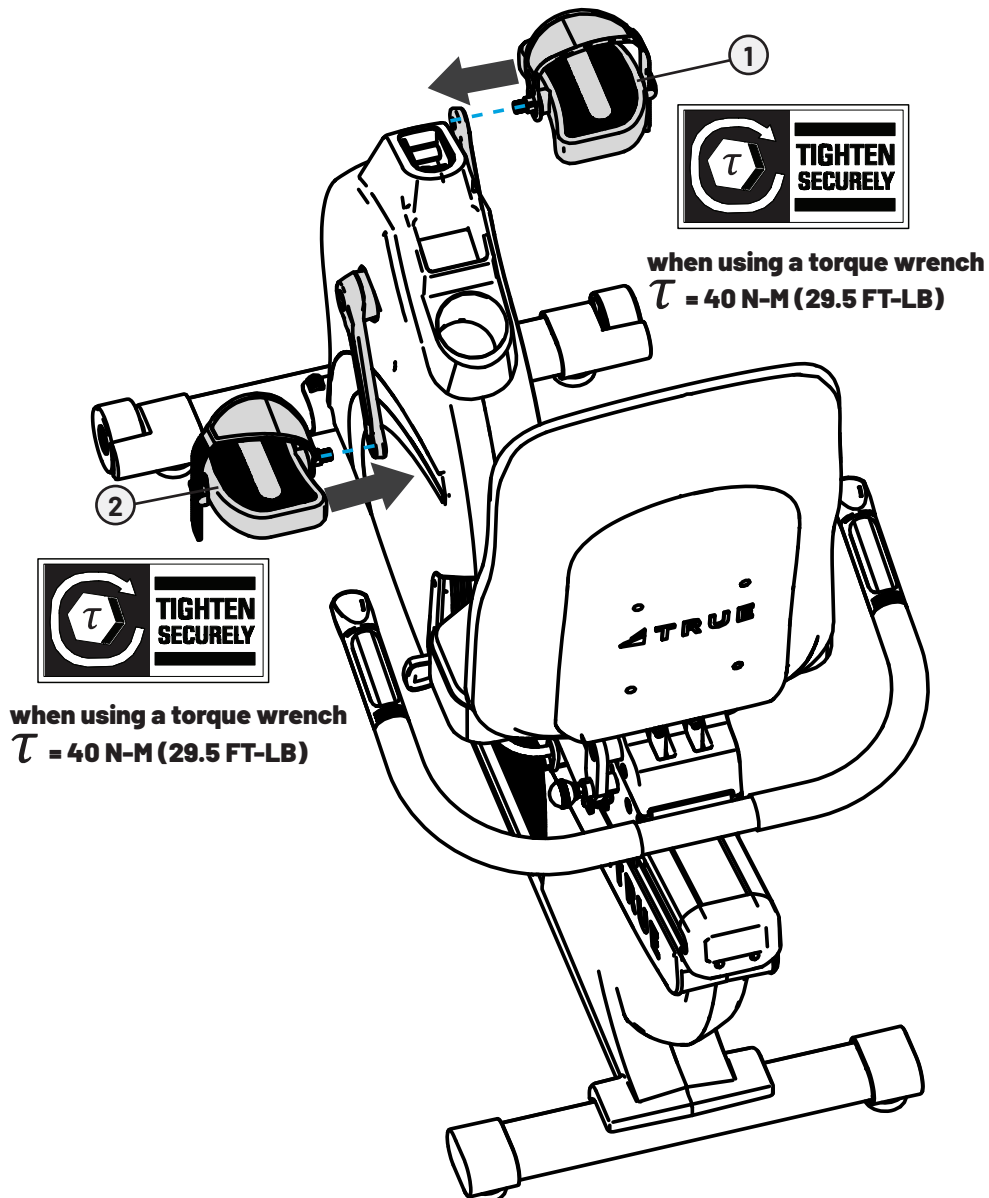

Step 9—Route Cables Up Front Mast

Parts Used in this Step			
Item	Part	Description	Qty
1	RCS0611-35	FRONT MAST ASSEMBLY	1
2	RCS0031BK	BOTTOM CONSOLE PLASTIC	1
3	RB0062BK	BOTTLE HOLDER	1

- A. Remove the storage dock from the base.

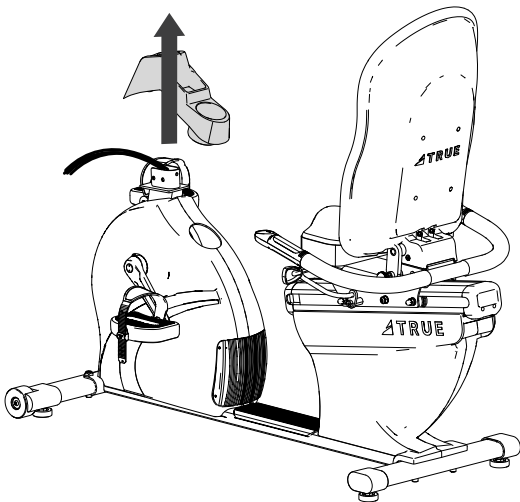

- B. Slide the bottom console cover and bottle holder up the console mast.

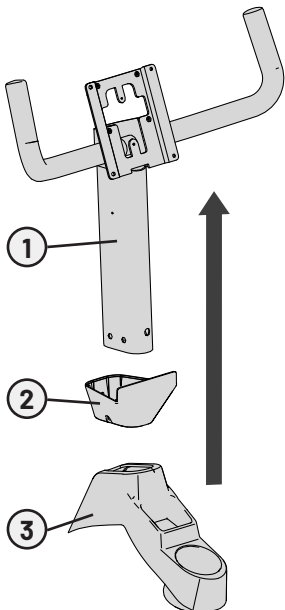

- C. Pull the cables coming from the front of the bike through the front mast using the provided pull tie.
IMPORTANT! DO NOT pinch the cables.
 Remove the pull tie from the cables and discard it.

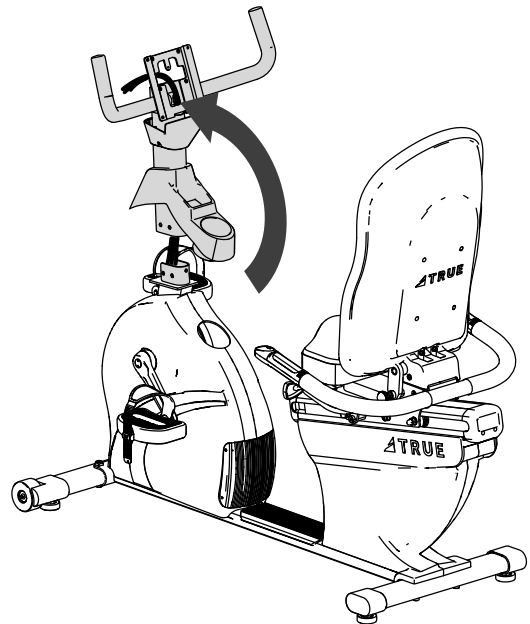

- D. Place the front mast onto the bike frame.

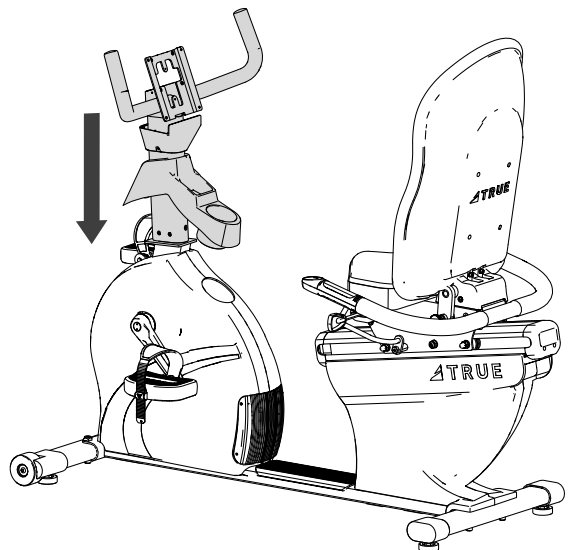

Step 10—Attach Front Mast

Tools Used in this Step	
6mm Allen Wrench	

Parts Used in this Step			
Item	Part	Description	Qty
1	RCS0611-35	FRONT MAST ASSEMBLY	1
2	RCS0404	BHCS, M10-1.5-20MM, ZP	5
3	FE0090	WASHER, SPRING, M10	5
4	RCS0369	WASHER, FLAT, 10MM X 20MM, T=2MM	5

- A. Using a 6mm allen wrench, secure the front mast to the bike frame using five button head cap screws, spring washers, and flat washers.

NOTE: Tighten the side console mast screws before the front screw.

IMPORTANT! DO NOT pinch the cables.

IMPORTANT! Make sure cables are clear from screws to avoid damage.

- B. Slide the bottle holder down over the bottom of the front mast tube.

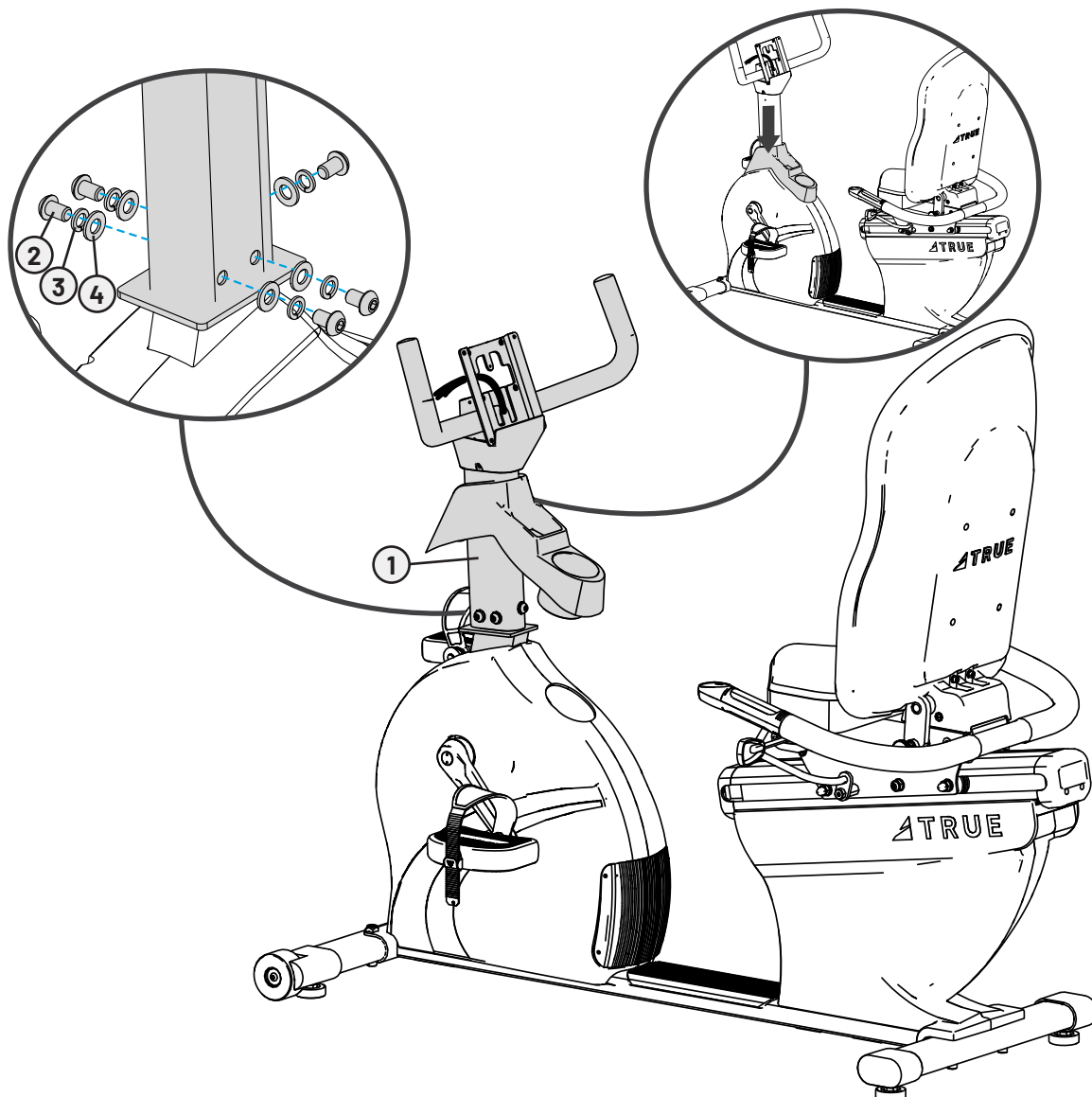

Step 11—Attach Console to Front Mast

Tools Used in this Step	
#2 Phillips Screwdriver	

- If the console has three screws (00567700 // SCREW, M4-.7 X 12 PPHMS SEMS) preassembled, remove and set aside these screws. They are not used in the installation. Remove and set aside the four screws (00567800 // SCREW, M5-.8X12 COMBO PHILLIPS/Common TRUSS HEAD - ACG BLACK) preassembled to the console.
- Connect the console and base cables: heart rate, I/O data, and ground (use the screw on the console mast to attach the ground cable from the console).

Ensure all cables are routed inside the console mast to avoid pinching cables.

IMPORTANT! Please see the console owner's manual for more detailed information on the console cable connections, machine setup, and use.

- Using a #2 Phillips screwdriver, secure the console to the console mast using the four screws (00567800).

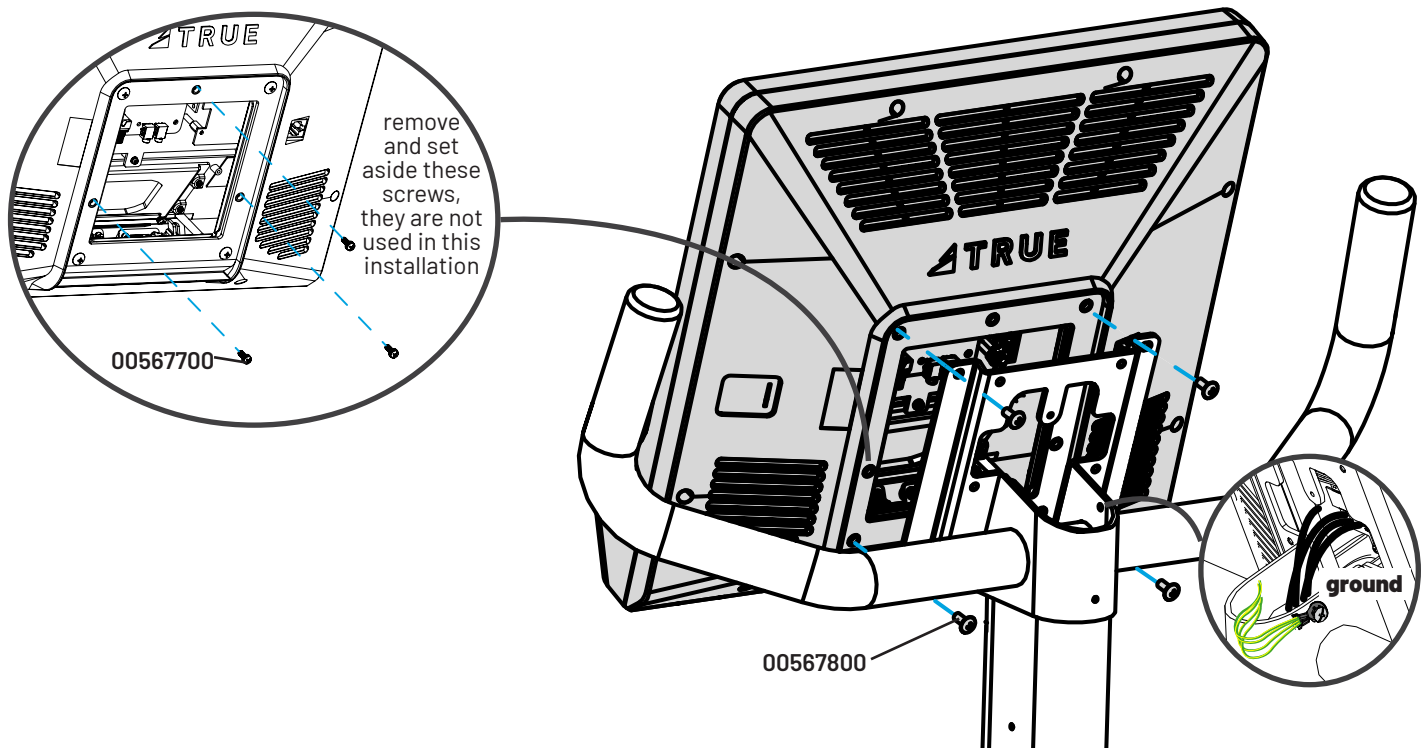

Step 12—Attach Console Covers

Tools Used in this Step	
#2 Phillips Screwdriver	

Parts Used in this Step			
Item	Part	Description	Qty
1	RCS0022BK	REAR CONSOLE COVER	1
2	RCS0031BK	BOTTOM CONSOLE PLASTIC	1
3	TCS4029	PHMS, M4-0.7 X 10MM, PHILLIPS	4

- Using a #2 Phillips screwdriver, attach the rear console cover to the front mast using two screws.
- Slide the bottom console cover up the front mast until it meets with the rear console cover.
- Using a #2 Phillips screwdriver, attach the bottom console cover to the front mast using the remaining two screws.

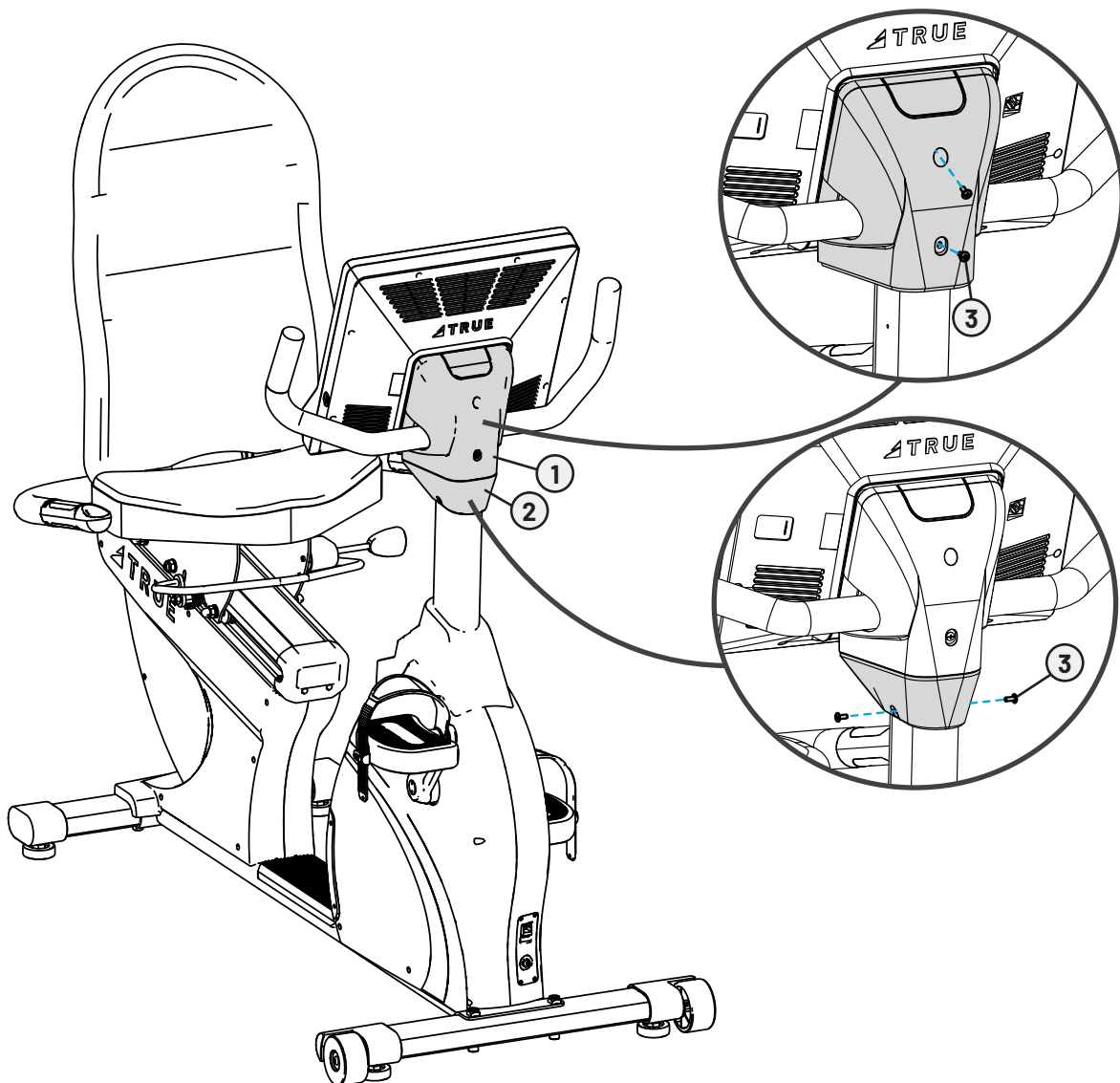

Step 13—Level the Machine

Tools Used in this Step

19mm Wrench



- A. Verify the bike is resting on the floor and not on any packaging materials.
- B. Using a 19mm wrench, adjust all four leveling feet until they contact the floor.
IMPORTANT! DO NOT adjust the leveling feet to such a height that they detach or unscrew from the machine.
- C. Verify all four lock nuts are securely tightened and flush against the bottom of the frame.

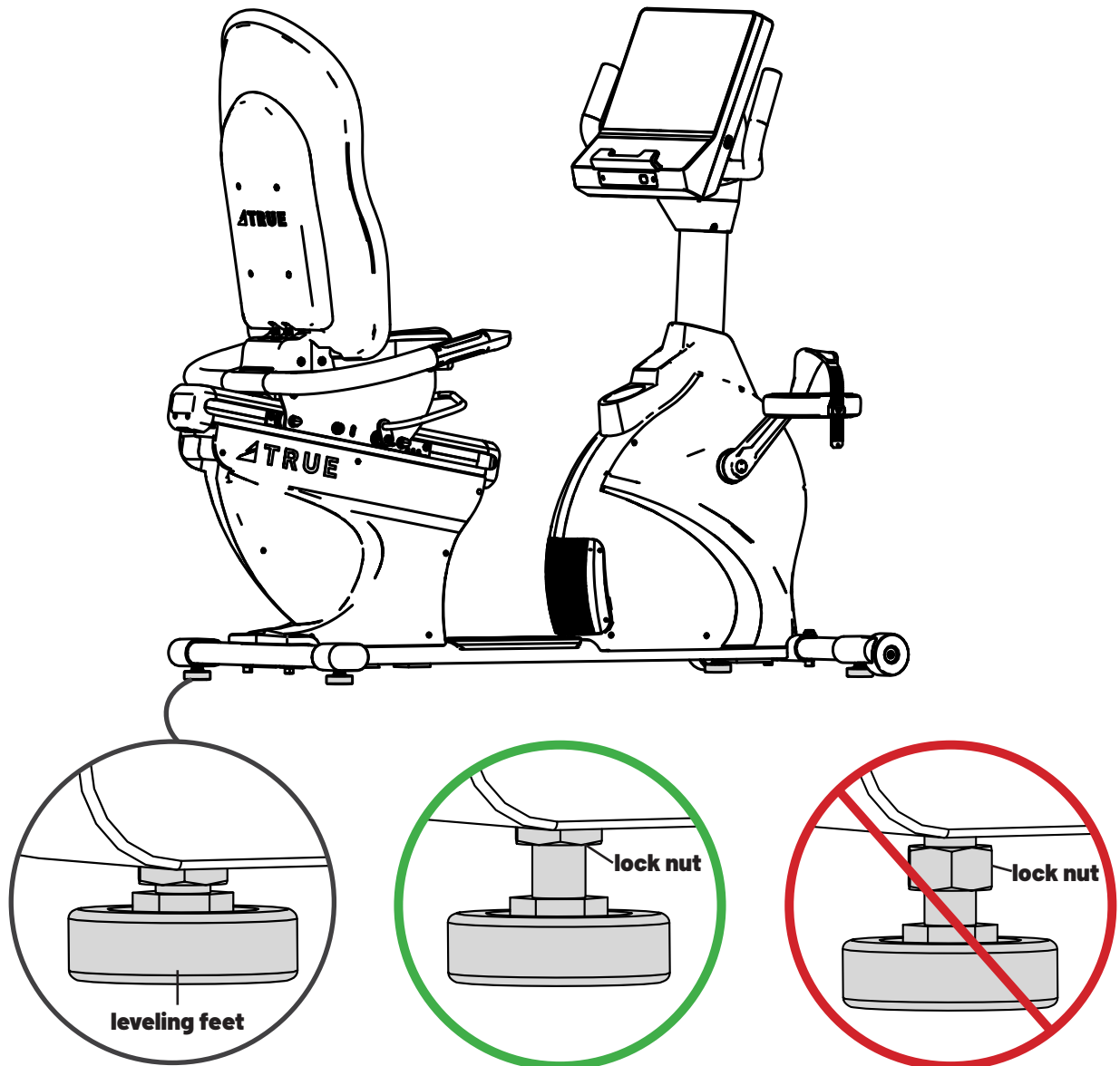

Step 14—Connect the Power Adapter

- A. Make the correct power connections for the base and console:
- If the console is a touchscreen use the 12V, 3A power adapter.
 - If the console is an LED use the 9V, 1.3A power adapter.
- B. Verify the console powers up and is configured for this machine. See the console owner's manual for more information.

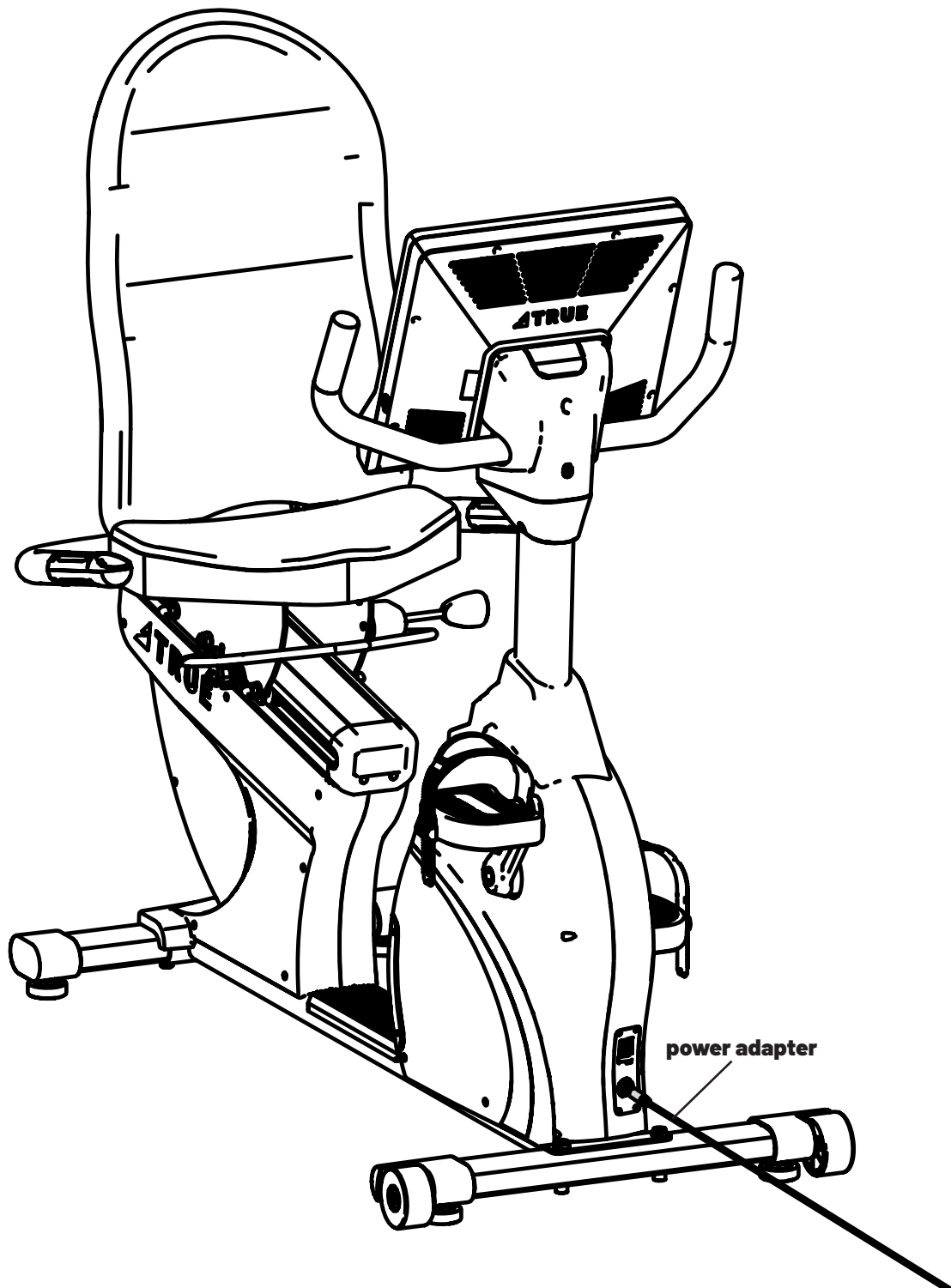

PRODUCT FEATURES

BASE OVERVIEW



Console Assembly—The console allows the user to set up a workout program and control the machine during a workout.

Contact Heart Rate Grips—Allows the user to check their heart rate without wearing a wireless chest strap.

Quick Access Control—Multi-function thumb controls.

Power Inlet—Where the power adapter plugs in to the machine to receive power from the wall outlet.

Leveling Feet—An adjustable system used to level the machine.

Pedals—Dual sided and weighted with integrated ratcheting strap.

Seat—Reclining fatigue resistant elastic mesh seat back with conforming lumbar support and 24 position settings.

CONSOLE OPTIONS

10" Touchscreen



16" Touchscreen



9" Touchscreen



LED



CARE AND MAINTENANCE

It is important to perform the minor maintenance tasks described in this section. Failure to maintain the bike as described here could void the TRUE Warranty. To reduce the risk of electrical shock, always unplug the unit from its power source before cleaning or performing any maintenance tasks.

INSPECTION

TRUE is not responsible for performing or scheduling regular maintenance or inspections. Users should inspect the bike daily. Look and listen for loose fasteners, unusual noises, worn or frayed power cords, and any other indications that the equipment may be in need of service. If any of these are noticed, obtain service. Do not attempt to use the bike until proper service has been performed or damaged parts have been replaced.

IMPORTANT! If you determine that the bike needs service, make sure it cannot be used inadvertently. Turn the unit off, and then unplug the power cord from its power source. Make sure other users know that the bike needs service.

To order parts or request service from a TRUE authorized service provider, please contact TRUE product support:

- www.truefitness.com
- 800.883.8783
- service@truefitness.com

CLEANING THE EQUIPMENT

AFTER EACH USE

- **Wipe Exposed Surfaces**—Use GymWipes™ Antibacterial wipes or spray a solution of 30 parts water to 1 part mild detergent to dampen a soft cloth and wipe all exposed surfaces.
- **Wipe Console**—Use an LCD/screen cleaner or spray a solution of 1 part 91% isopropyl alcohol and 1 part water to dampen a soft cloth and wipe the surface of the console. This helps remove fingerprints, dust, and dirt.

WEEKLY

- **Vacuum**—Use a vacuum to remove any dust or dirt that might have accumulated under or around the bike.

⚠CAUTION:

Do not use any acidic cleaners. Doing so will weaken the paint or powder coatings and may void the TRUE Warranty. Never pour water or spray liquids on any part of the machine. Allow the machine to dry completely before using. Frequently vacuum the floor underneath the unit to prevent the accumulation of dust and dirt, which can affect the smooth operation of the unit.

LEVELING THE MACHINE

The bike has adjustable leveling feet. Make sure the machine is level. If the machine is placed on an uneven surface, adjusting the feet can help, but may not completely compensate for extremely uneven surfaces.

SCHEDULING QUARTERLY PREVENTATIVE MAINTENANCE

TRUE recommends scheduling quarterly preventative maintenance with a qualified service provider. Please contact your dealer or visit www.truefitness.com to contact a local TRUE authorized service provider.

QUARTERLY PREVENTATIVE MAINTENANCE

- Record time, distance, and hours from the console.
- Check error log in console.
- Move bike and vacuum underneath.
- Inspect all fasteners.
- Inspect all electrical connections.
- Inspect all components for abnormal or premature wear.

⚠CAUTION: Only use TRUE authorized service providers. Using non-authorized service providers could void the TRUE Warranty.

LONG TERM STORAGE

When the bike is not in use for any length of time, turn it off. Make sure that the power cord is unplugged from the power source and is positioned so that it will not become damaged or interfere with people or other equipment.

CLEANING AND STORING THE CHEST STRAP

Clean the chest strap using a sponge or soft cloth dampened in mild soap and water. Dry the surface thoroughly with a clean towel. Store the chest strap in a place where it remains free of dust and dirt. Be sure to protect the chest strap from extreme temperatures. Do not store it in a place that may be exposed to temperatures below 32° F (0° C).

ADDITIONAL INFORMATION

TROUBLESHOOTING

This troubleshooting information is intended to assist in diagnostics only and is not all inclusive. Technical specifications, error codes, and programming are subject to change without notice. TRUE accepts no liability for any damage or loss suffered by persons whom rely wholly or in part on any description or statement contained within this manual. Please visit www.truefitness.com to obtain the most recent version of all manuals and contact TRUE product support (800-883-8783) for assistance with troubleshooting and diagnostics.

Malfunction	Possible Cause	Corrective Action
No power	<ul style="list-style-type: none"> A. Unit turned off B. Damaged power cord C. Power cord not fully seated in socket D. No power at outlet E. Tripped circuit breaker 	<ul style="list-style-type: none"> A. Verify the On/Off switch is at the ON position B. Replace power cord C. Inspect power connection at the unit and outlet D. Use a voltmeter to verify power at outlet E. The location of the circuit breaker is next to the On/Off switch—verify the circuit breaker is not open—if the breaker is open, reset it
Unit resets or pauses randomly	<ul style="list-style-type: none"> A. Damaged power cord B. Power cord not fully seated in socket C. Insufficient power D. Error code is displayed on console E. Pinched or loose main communication cable F. No User Present displayed on screen 	<ul style="list-style-type: none"> A. Replace power cord B. Inspect power connection at the unit and outlet C. Verify output voltage from 20A outlet with a voltmeter D. Contact TRUE product support E. Contact TRUE product support F. User weight must be over 90 lbs—verify No User Present settings in console
Heart rate displaying erratically or not displaying	<ul style="list-style-type: none"> A. Transmitter belt contacts are not making good contact with the skin B. Contacts on the transmitter belt are not moist C. Transmitter belt is not within 3 feet (1 meter) of the heart rate receiver D. The battery inside the transmitter belt is depleted E. Another user wearing a compatible transmitter strap is within 3 foot (1 meter) of the unit F. Environmental interference from high voltage power lines, computers, motor driven appliances, cell/cordless phone, or WiFi router 	<ul style="list-style-type: none"> A. Re-adjust the transmitter belt so that it is in full contact with the skin B. Moisten the contacts on the transmitter belt C. Adjust your position so that you are within 3 feet (1 meter) of the console D. Replace the transmitter belt with a compatible transmitter belt E. Move the units so that there is more space between them F. Move the unit to another position within the room or move the cause of the interference until heart rate reading are stable—if the probable source of interference is plugged into the same outlet move the suspect source to another outlet
Rubbing or knocking sound from unit when in operation	<ul style="list-style-type: none"> A. Uneven floor B. Loose hardware C. Loose pedal D. Bearings may be damaged E. Brake assembly may be damaged F. Drive belt may be misaligned 	<ul style="list-style-type: none"> A. Use leveling feet to make adjustments B. Inspect and tighten hardware C. Inspect and tighten pedals D. Contact TRUE product support E. Contact TRUE product support F. Contact TRUE product support

ATTENTION OWNER'S: To ensure you get the most out of your purchase and receive the full benefits of our warranty, you must register your product within 45 days of purchaser's receipt of this product.

WARRANTY

RRI-0B IN HOME RESIDENTIAL WARRANTY

WARRANTY ITEM	DURATION
Frame*	25 Years (with registration)
Parts	10 Years
Console 10" and 16" Touchscreen	3 Years
Console 9" Touchscreen	7 Years
Console LED	10 Years
Labor**	1 Year (with registration)
Wear Items***	90 Days

Warranty does not cover damage or equipment failure resulting from or caused by improper assembly/installation, accident, misuse, abuse, unauthorized modification, or failure to provide reasonable and necessary maintenance.

*Frame is the serialized base of the unit and does not include paint or coatings. Frame warranty will equal that of parts warranty unless, within 45 days of purchaser's receipt of this Product (A) the warranty is registered on-line or (B) if the form provided with equipment is filled in, signed by the original purchaser, and mailed to TRUE. If a valid receipt is not available, the Limited Frame Warranty period begins from the date of manufacture on the originally purchased equipment.

**Labor warranty is available for equipment located within United States. TRUE Fitness equipment is automatically covered under a 6-month Limited Labor Warranty. This 6-month Limited Labor Warranty begins from the date of purchase shown by a valid receipt. If a valid receipt is not available, the 6-month Limited Labor Warranty period begins from the date of manufacture on the originally purchased equipment.

***Wear Items include: batteries, covers, caps, badges, paint, pedal straps, toe clips, elliptical pedal inserts, foot pads, Coax/TV, HDMI, USB, mirroring or Ethernet connections, and safety key.

All TRUE Fitness products are distributed by TRUE and are warranted to the original product purchaser and the parts of the TRUE product (the "Product") listed below. During the applicable Warranty Period, the Product, under normal use and service, shall be free of manufacturing defects in workmanship and materials.

NOTE:

- Standard shipping is included with warranty part replacement.
- Shipping for warranty frame or replacement is included for the period of three years from the original date of purchase.

All Warranty Items are "LIMITED"

- This limited warranty does not cover damage or equipment failure resulting from or caused by improper assembly/ installation, failure to follow instructions and warnings in owner's manual, accident, misuse, abuse, unauthorized modification, failure to provide reasonable and necessary maintenance, software version upgrades, compatibility with third party/aftermarket hardware, software, applications, or websites.

- TRUE's liability shall under no circumstances exceed the actual amount paid by you for the product, nor shall TRUE under any circumstances be liable for any consequential, incidental, special or punitive damages or losses, whether direct or indirect.
- Some states or countries do not allow the exclusion or limitation of incidental or consequential damages, so the above limitation or exclusion may not apply to you.
- TRUE will neither assume nor authorize any person to assure for us any other obligation or liability concerning the sale of this Product. Under no circumstances shall TRUE be liable under this warranty, or otherwise, of any damage to any person or property, including any lost profits or lost savings, for any special, indirect, secondary, incidental, or consequential damages arising out of the use of or inability to use this Product.
- This limited warranty, which is given expressly and in lieu of all other express warranties, constitutes the only warranty made by TRUE.
- The remedies described herein are your sole and exclusive remedies and TRUE's entire liability for any breach of this limited warranty.
- No one is authorized to change, modify, or extend the terms of this limited warranty.
- This limited warranty is in lieu of all other warranties of any kind either expressed or including but not limited to implied warranties of merchant.
- This limited warranty applies to the product only while the product remains in the possession of the original purchaser and is not transferable.
- This limited warranty becomes VALID ONLY if the Product is initially assembled/installed by a TRUE authorized dealer/ technician (if anyone other than a TRUE authorized dealer/ technician initially assembles and installs the Product, this limited warranty will be void unless the written authorization of TRUE is first obtained).
- The "Warranty Period" for this limited warranty shall be for the duration forth in the applicable charts, beginning from the date of original purchase; provided, however, except to the extent prohibited by applicable law, the "Warranty Period" shall only be 6-months for Labor, 10-years for Frame (from the date of original purchase) unless, within 45 days of purchaser's receipt of this Product (A) the warranty is registered on-line or (B) if the form provided with equipment is filled in, signed by the original purchaser, and mailed to TRUE.
- All serial numbers must be intact on the Product for this limited warranty to be valid.
- Installation or download of any 3rd party or after-market products will result in voided warranty. This includes, but is not limited to, electrical and mechanical parts, software, or applications.
- TRUE will ship to an authorized service provider any new or rebuilt replacement part or component, or at our option, replace or refund the Product.
- Replacement parts are warranted for the remaining portion of the original warranty period.
- Proof/receipts of necessary maintenance may be required within 30 days of requested warranty part or service.
- This limited warranty does not apply to the performance of the heart rate accuracy will not be warranted as performance varies, based on user's physiology, age, method of use, and other external factors.

ATTENTION OWNER'S: To ensure you get the most out of your purchase and receive the full benefits of our warranty, you must register your product within 45 days of purchaser's receipt of this product.

WARRANTY REGISTRATION

Thank you for purchasing a TRUE product!

To ensure you get the most out of your purchase and receive the full benefits of our warranty, **you must register your product within 45 days of purchaser's receipt of this product.**

How to register your product:

- **Online:**
Simply visit our website at truefitness.com and register your product warranty in one simple step.
- **QR Code:**
Scan the QR code below with your smartphone to be taken directly to the registration page.



- **By Mail:**
Complete the information below and mail to:
TRUE Product Support
865 Hoff Road
St. Louis, MO 63366

PLEASE RETAIN THIS PORTION FOR YOUR RECORDS

BASE SERIAL NUMBER:

CONSOLE SERIAL NUMBER:



Warranty Registration

Base Serial Number

Console Serial Number (if applicable)

NOTE: Some base units require a console serial number.

Purchase Date

Company (if applicable)

Customer Name (First and Last)

Email Address

Phone Number

Street Address

City

State

Postal Code

Country



CONTACT US
service@truefitness.com
1.800.883.8783

865 Hoff Road
St. Louis, MO 63366

[TRUEFITNESS.COM](https://www.truefitness.com)

